

# User Manual



## ***Solar Hybrid Inverter***

HEBP48150U320-H  
HEBP48160U340-H  
HEBP48180U380-H





## **READ THE INSTRUCTIONS COMPLETELY BEFORE OPERATING THE EQUIPMENT**

**[Disregarding these instructions could result in permanent damage to the unit]**

Due to product iteration and upgrade requirements, the equipment specifications, parameters and functional configurations are subject to timely updates and adjustments. The latest version of the user manual can be obtained via the official website:

<https://www.szshuori.com>. We have made every effort to ensure the completeness and accuracy of the content in this document; however, SRNE reserves the right to modify product and document content without prior notice.

Users must strictly follow the provisions of this manual throughout the entire process of equipment installation, operation and maintenance. SRNE shall not be liable for any consequences arising from failure to operate in accordance with the requirements specified in this manual. Meanwhile, SRNE shall only be responsible for the inverter equipment supplied herewith, and shall not assume joint and several liability for any associated upstream or downstream systems related to the equipment.

### **The Company shall not be liable for damage caused by :**

- ① Damage caused by improper use or use in a wrong location.
- ② PV modules with an open-circuit voltage exceeding the maximum permissible voltage.
- ③ Damage caused by the operating temperature exceeding the restricted operating temperature range.
- ④ Dismantling and repair of the inverter by unauthorised persons.
- ⑤ Damage caused by force majeure: damage during transport or handling of the inverter.



Please scan the QR code  
to download the user manual

# Contents

<b>1. Safety Precautions</b>	1
1.1 How to Use This Instruction Manual	1
1.2 Symbols in This Manual	1
1.3 Safety Instructions	1
<b>2. Product Introduction</b>	2
2.1 Product Description	2
2.2 Product Features	2
2.3 System Connection Diagram	3
2.4 Product Overview	5
2.5 Product Size	6
<b>3. Installation</b>	7
3.1 Part List	7
3.2 Installation Instructions	8
3.2.1 Installation Location Selection	8
3.2.2 Mounting the Inverter	9
3.2.3 Removing the Terminal Protection Cover	10
<b>4. Connection Instructions</b>	10
4.1 Split-phase Mode	10
4.2 Cable & Circuit Breaker Selection	11
4.3 Grid & Load & Generator Connection	12
4.4 Battery Connection	13
4.5 PV Connection	14
4.6 Dry Contact Connection	15
4.7 Grounding Connection	16
4.8 Inverter Start	16
4.9 Parallel Connection	16
4.9.1 Parallel Operation	16
4.9.2 Precautions for Connecting Parallel Connection Cables	17
4.9.3 Schematic of Split-phase Parallel Operation	18
4.9.4 Schematic of Three-phase Parallel Operation	20
<b>5. Operation</b>	24
5.1 Operation and Display Panel	24
5.2 Setting Parameters	27
5.2.1 Basic Setup	29
5.2.2 Work Mode Setup	29
5.2.3 Battery Setup	32
5.2.4 Grid Connection Setup	35
5.2.5 Advanced Setup	38
5.2.6 LCD Display WiFi Setting	40
5.2.7 Firmware Upgrade via USB Drive	41
5.3 Time-slot Charging/Discharging Function	41
5.4 Battery Parameters	43
5.4.1 Lead-acid Battery	43
5.4.2 Lithium-ion Battery	43
<b>6. Communication</b>	44
6.1 Product Overview	44
6.2 USB-1 Port	44
6.3 USB-2 Display Port	45
6.4 WiFi Communication Function	45
6.5 CAN/RS485/BMS1 Port	45
6.6 CAN Port	46
6.7 DRM(Only Australia)	46
6.8 External CT Prot	46
6.9 DIP Switch Configuration	48
6.10 Dry Contact Function	48
6.11 Remote Monitoring	48
6.11.1 Download App	49
6.11.2 Stick Logger Installation	49
6.11.3 SOLARMAN Smart APP Operation	50
6.11.4 Plant Detail	52
6.11.5 Abnormal State Processing	54
<b>7. Fault and Remedy</b>	56
7.1 Fault Codes	56
7.2 Troubleshooting	58
<b>8. Protection and Maintenance</b>	59
8.1 Protection Functions	59
8.2 Maintenance	60
8.3 Storage	60
<b>9. Datasheet</b>	61





# 1. Safety Precautions

## 1.1 How to Use This Instruction Manual

This manual contains important product information, guidelines, and operating and maintenance instructions.

Read the manual and other related documents before performing any operation on the inverter. Documents must be stored carefully and be available at all times.

## 1.2 Symbols in This Manual

	<p>DANGER indicates a hazardous situation which, if not avoided, will result in death or serious injury.</p>
	<p>WARNING indicates a potentially hazardous situation which, if not avoided, could result in death or serious injury.</p>
	<p>CAUTION indicates a potentially hazardous situation which, if not avoided, may result in minor or moderate injury.</p>
	<p>NOTICE provides important information related to the operation of the product.</p>

## 1.3 Safety Instructions

**WARNING:** This chapter contains important safety and operating instructions. Read and keep this manual for future reference.

- Be sure to comply the local requirements and regulation to install this inverter.
- Beware of high voltage. Please turn off the switch of each power sources before and during the installation to avoid electric shock.
- For optimum operation of this inverter, please follow required specification to select appropriate cable size and necessary protective device.
- Do not connect or disconnect any connections when the inverter is working.
- Do not open the terminal cover when the inverter working.
- Make sure the inverter is well grounding.
- Never cause AC output and DC input short circuited.
- Do not disassembly this unit, for all repair and maintenance, please take it to the professional service center.
- Never charge a frozen battery.

## 2. Product Introduction

### 2.1 Product Description

The product is a new type of solar energy storage inverter that integrates solar energy storage, utility charging, energy storage, and AC sine wave output.

It is highly compatible with various application scenarios, including residential energy storage systems.

It adopts DSP control and achieves high response speed, reliability, and compliance with an industrial standard through an advanced control algorithm. It provides users with a reliable and efficient energy conversion solution.

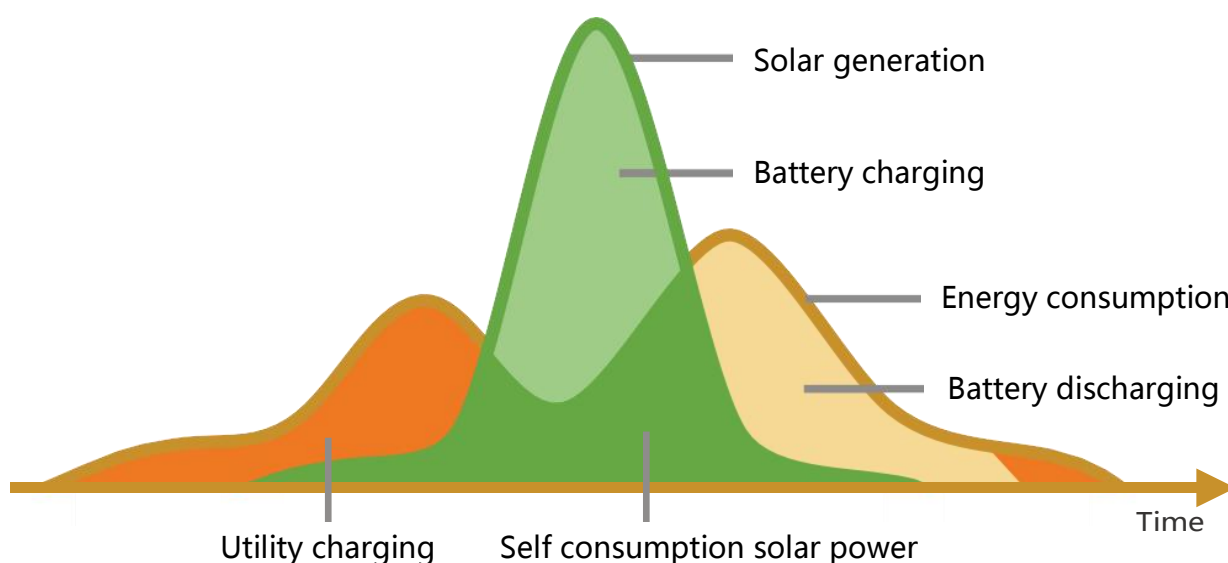

### 2.2 Product Features

- Supports lead-acid battery and li-ion battery connections.
- Supports smart load function with intelligent load connection control based on battery status.
- Supports AC coupling function for flexible integration into existing PV systems.
- When the lithium-ion battery is dormant, it is equipped with three activation functions; the connection of mains, generator or PV power supply can trigger the activation of the battery.
- Support split-phase or three-phase pure sine wave output.
- Supports phase voltage adjustment in the range of 100Vac, 105Vac, 110Vac, 115Vac, 120Vac, 127Vac, and 133Vac.
- Supports three PV inputs, with the function of simultaneously tracking the maximum power charging or carrying capacity of three MPPT.
- Three MPPT channels with a tracking efficiency of up to 99.9% and a maximum single-channel current of 42A, perfectly compatible with high-power PV modules.

- Supports PV-only charging and grid-PV hybrid charging modes.
- With time-slot charging and discharging setting function, it helps users to take advantage of peak and valley tariffs and save electricity costs.
- Energy-saving mode function to reduce no-load energy losses.
- With two output modes of utility bypass and inverter output, with uninterrupted power supply function.
- LCD large screen dynamic flow diagram design, easy to understand the system data and operation status.
- Multi-functional protection logic, including short-circuit protection, overcurrent protection, overvoltage protection, undervoltage protection, overload protection, and over-temperature protection.
- Support CAN, USB, and RS485 communication.

## 2.3 System Connection Diagram

The following figure illustrates the product's system application scenario. A complete system consists of the following components:

- **PV Modules:** Converts light energy into DC energy, which can be used to charge the battery via an inverter or directly inverted into AC power to supply the load.
- **Grid:** Connected to the mains AC input, supplying power to loads while charging batteries. The system can operate off-grid when batteries and PV modules power the loads.
- **Battery:** The role of the battery is to ensure the normal power supply of the system loads in case of insufficient photovoltaic and no utility power.
- **Home Load:** Connects to a variety of home and office loads including refrigerators, lamps, TVs, fans, air conditioners and other AC loads.
- **Generator/Smart Load/Micro-inverter Input:** When connected to an AC generator, supplies power to loads and charges batteries simultaneously. Without generator connection, this interface can be configured as a Smart Load output to power loads. When connected to micro-inverters, it supplies power to loads and charges batteries concurrently.
- **Inverter:** It is the energy conversion device of the whole system.

**Note: The actual application scenario determines the specific system cabling.**

**System Wiring Diagram 1**

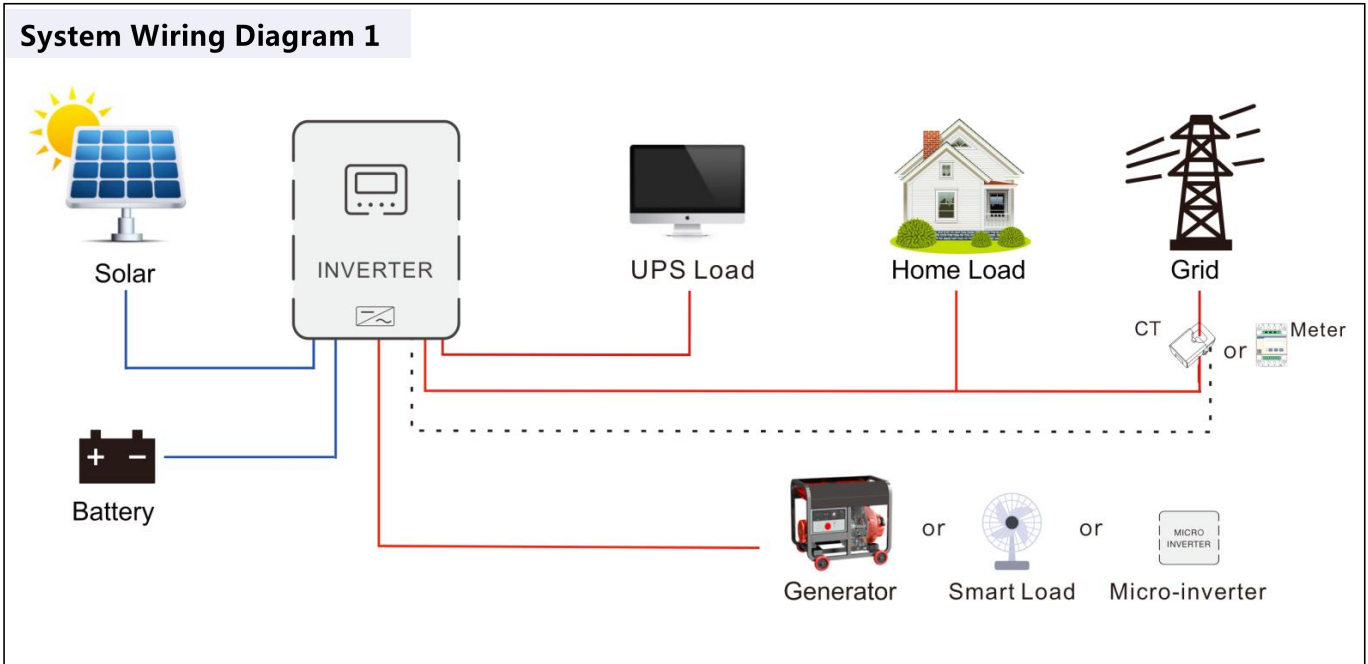

**System Wiring Diagram 2**

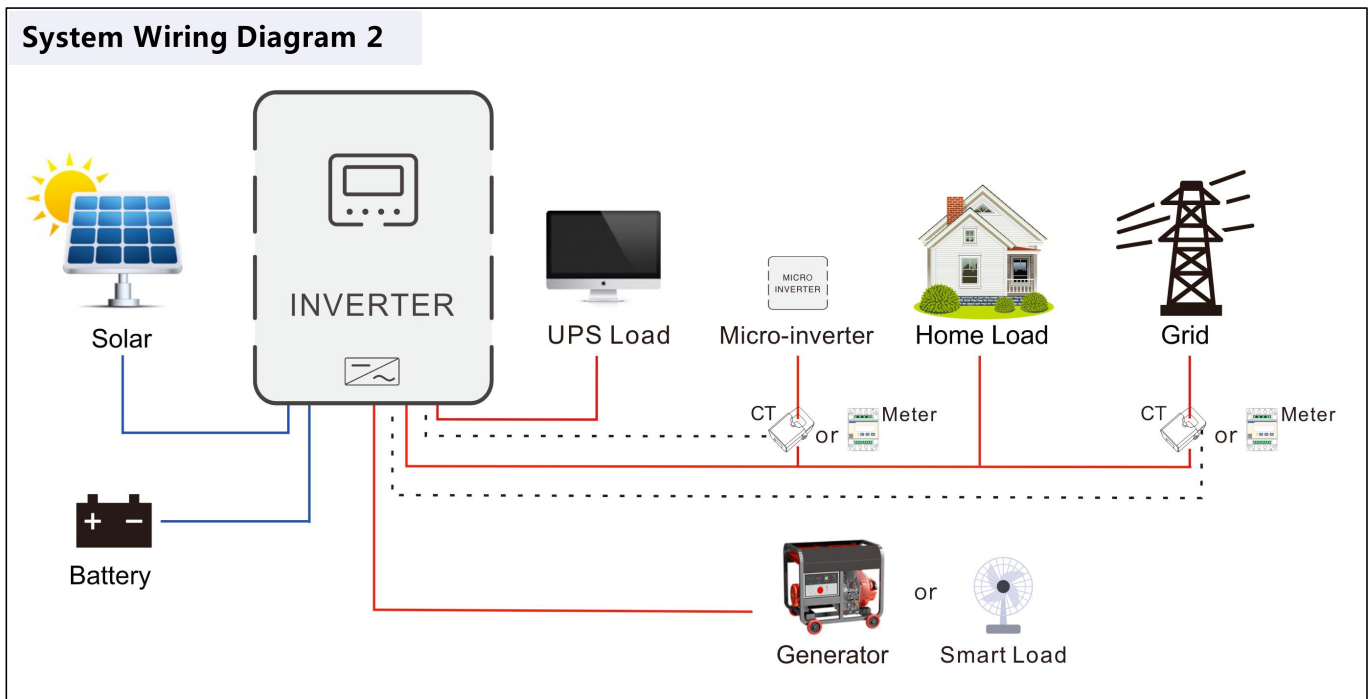

## 2.4 Product Overview

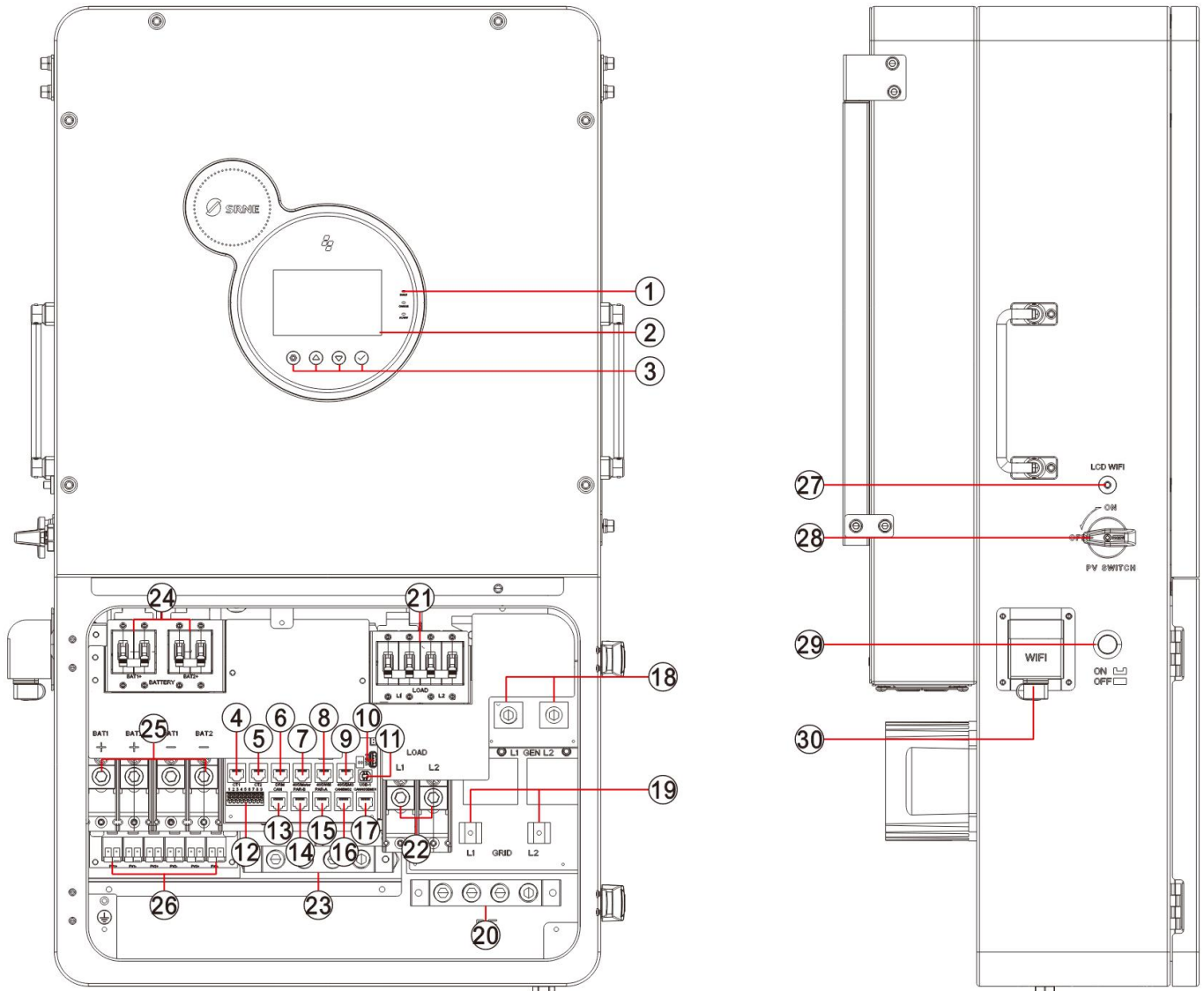

1	LED Indicator Light	2	LCD Screen	3	Operation Button
4	Grid CT1	5	Micro-inverter CT2	6	DRM Port
7	485/Meter Port	8	485/WiFi Port	9	485/EMS Port
10	Display USB-2 Port	11	USB-1 Port	12	Dry Contact Interface SC1
13	CAN Communication Port	14	Parallel Port-B	15	Parallel Port-A
16	CAN/BMS2 Port	17	CAN/485/BMS1 Port	18	Generator Input (L1+L2)
19	Grid Input (L1+L2)	20	PE Terminal	21	Load AC Circuit Breaker
22	Load Output (L1+L2)	23	N Line Terminal	24	Battery Circuit Breaker
25	Battery Input	26	PV Input	27	LCD WiFi Antenna
28	PV DC Circuit Breaker	29	Start Switch	30	WiFi Module



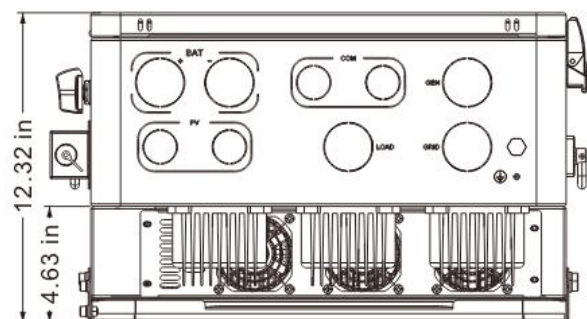
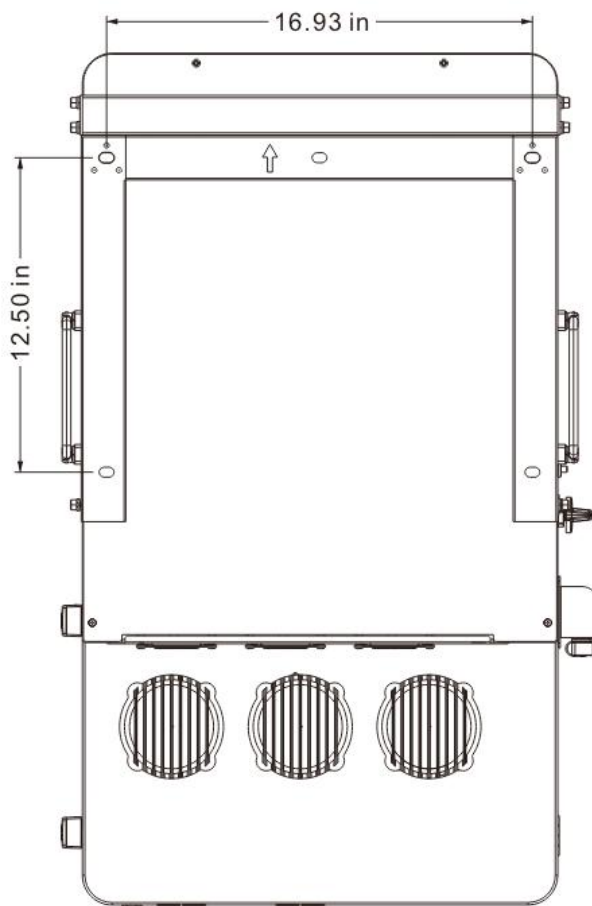
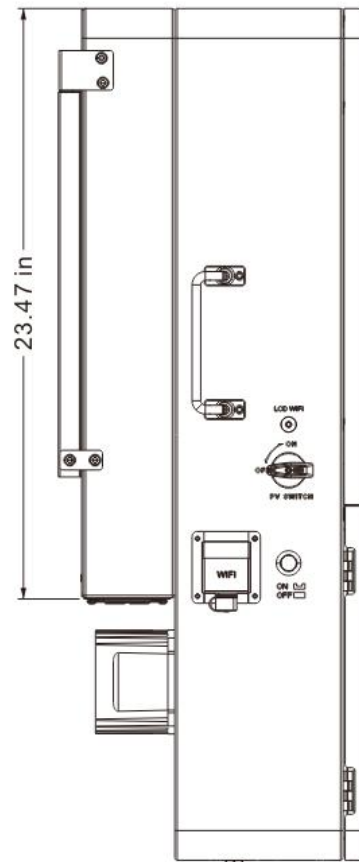
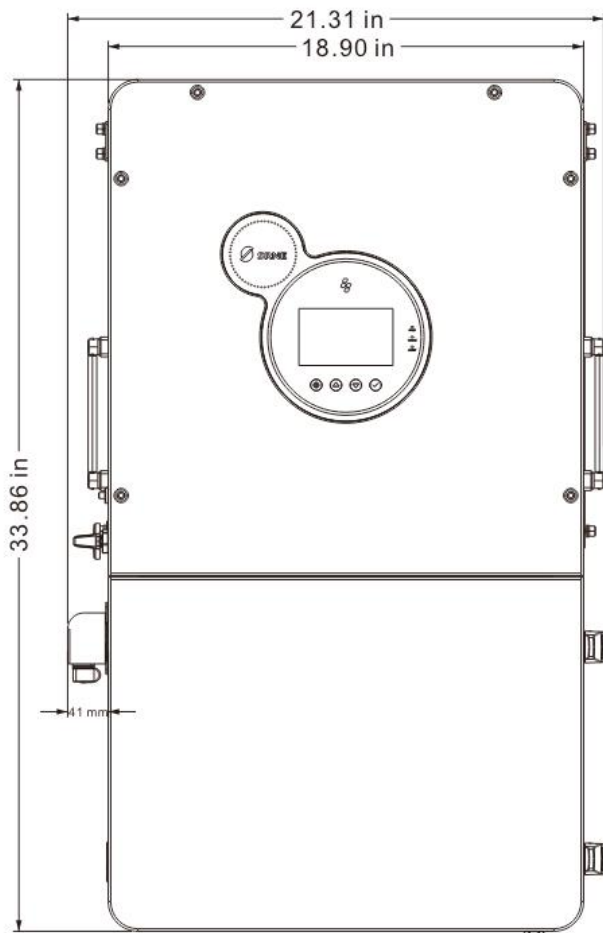







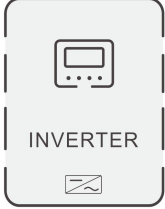

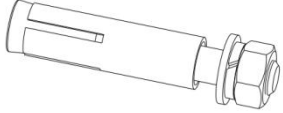
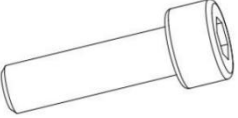
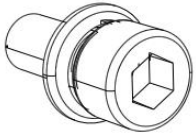
## 2.5 Product Size

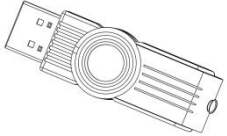
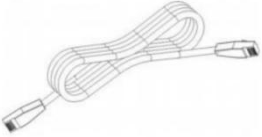
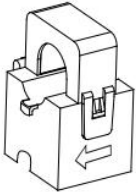
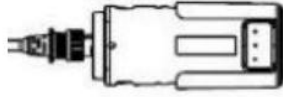
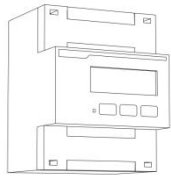

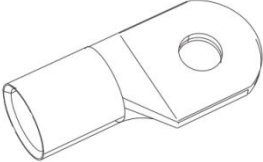
# 3. Installation

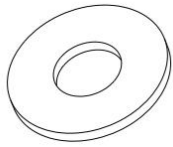
## 3.1 Part List

Please check the equipment before installation. Make sure that there is no damage to the packaging. You should have received the following items in the package:

 <p>Hybrid inverter x 1pcs</p>	 <p>Wall mount bracket x 1pcs</p>	 <p>Hex Key_L-Type_5mm/ Hex Key_L-Type_8mm x 1pcs / x 1pcs</p>	 <p>Expansion screws M8*60mm x 5pcs</p>
 <p>Spare screw M6*18mm x 1pcs</p>	 <p>Hex socket head triple-combination screws M6*16 x 2pcs</p>	 <p>Keys x 4pcs</p>	 <p>USB flash drive x 1pcs</p>
 <p>Parallel connection cable x 1pcs</p>	 <p>CT x 1pcs</p>	 <p>WiFi module x 1pcs</p>	 <p>Meter (Optional) x 1pcs</p>
 <p>WiFi antenna x 1pcs</p>	 <p>Cold-pressed terminal SC70-8 x 4pcs</p>	 <p>M8 socket wrench x 1pcs</p>	 <p>M8 flat washer x 5pcs</p>
 <p>User manual x 1pcs</p>	 <p>Quality certificate x 1pcs</p>	 <p>Outgoing inspection report x 1pcs</p>	 <p>Warranty Card x 1pcs</p>

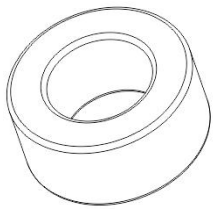

Magnetic ring  
(Model: T58x38x20)  
x 2pcs

(Model: T40x25x15)  
x 6pcs

(Model: T36x23x15C)  
x 2pcs

 **NOTICE**

**Introduction:** Anti-interference magnetic rings

**Function:** When external wiring is long or there is uncertain electromagnetic interference in the usage environment, it is recommended to install magnetic rings on the wires. Magnetic rings can be directly slipped onto the wires or wrapped around them in a single loop.

- 2 magnetic rings of model T58x38x20, primarily used on the battery side to suppress interference generated during battery charging and discharging.
- 6 magnetic rings of model T40x25x15, primarily used on power lines for mains power, generator loads, and photovoltaic systems to suppress external interference.
- 2 magnetic rings of model T36x23x15C, primarily used to be fitted onto various communication lines (such as WiFi lines, external CT lines, parallel machine lines, 485 lines, CAN lines, etc.) to suppress interference during signal transmission.

## 3.2 Installation Instructions

### 3.2.1 Installation Location Selection

The product is suitable for outdoor use (protection class IP65). Please note the following before selecting the installation location:

- Choose the solid wall to install the inverter.
- Mount the inverter at eye level.
- Adequate heat dissipation space must be provided for the inverter. (specific requirements: the heat dissipation distance above and below the inverter should be  $\geq 7.87$  in, and the distance on both left and right sides should be  $\geq 19.69$  in).
- The ambient temperature should be between  $-40\sim 60^{\circ}\text{C}$  ( $-40\sim 140^{\circ}\text{F}$ ) to ensure optimal operation.

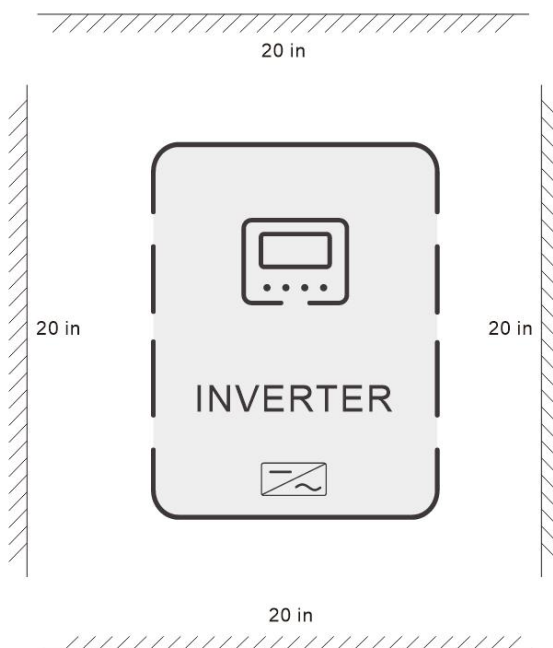

 **DANGER**

- Do not install the inverter where highly flammable materials are near by.
- Do not install the inverter in potential explosive areas.
- Do not install the inverter with lead-acid batteries in a confined space.

 **CAUTION**

- Do not install the inverter in direct sunlight.
- Do not install or use the inverter in a humid environment.

## 3.2.2 Mounting the Inverter

- **Step 1:** Determine the positions for drilling holes, ensure the position of holes are level, then mark them with a marker pen, use the hammer drill to drill holes on the wall. Keep the hammer drill perpendicular to the wall, do not shake when drilling, so as not to damage the wall. If the error of the hole is too big, you need to reposition.
- **Step 2:** Insert M8\*60 expansion bolt vertically into the hole and pay attention to the insertion depth of the expanding bolt (should be deep enough)
- **Step 3:** Align the wall hanger with the position of holes, fix the wall hanger on the wall by tightening the expansion bolt with nuts.
- **Step 4:** Align the mounting holes and attach the inverter to the wall bracket, securing it in place with safety screws.

Step 1

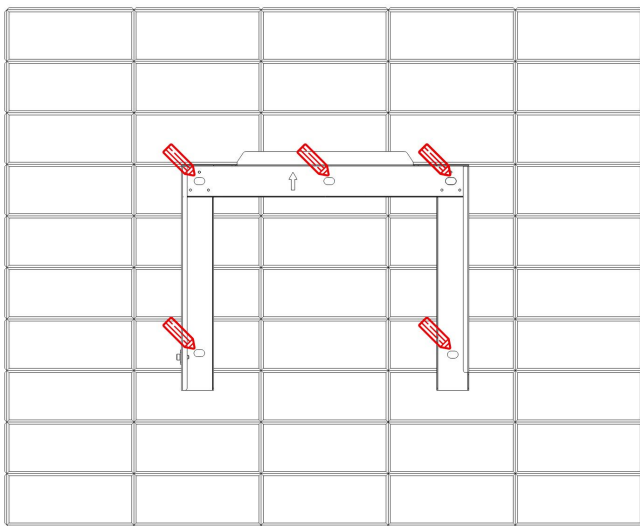

Step 2

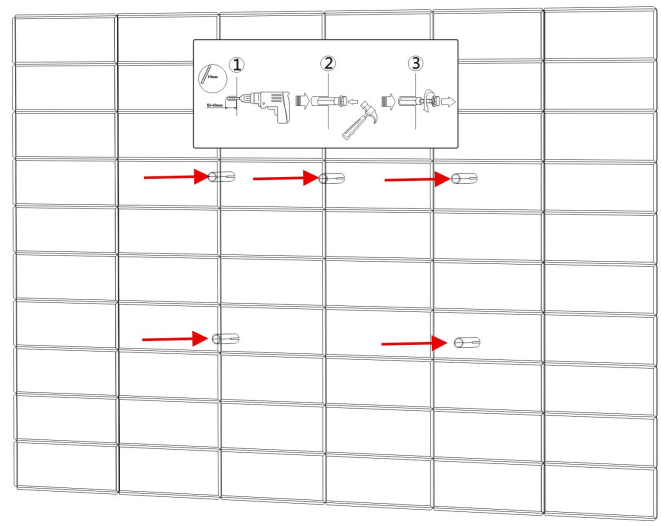

Step 3

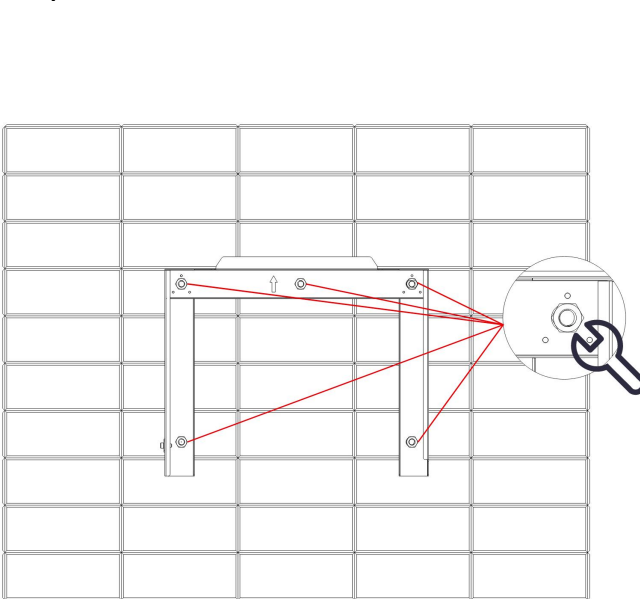

Step 4

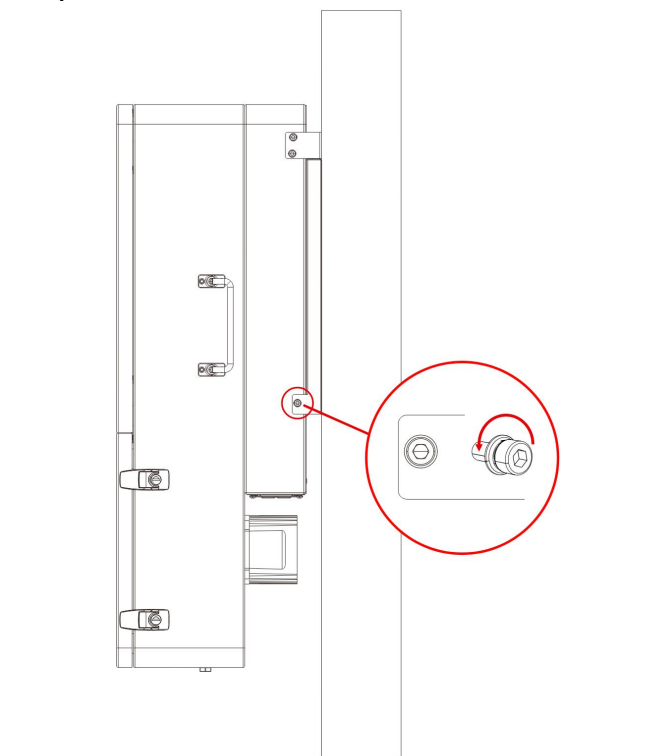

### 3.2.3 Removing the Terminal Protection Cover

Use the key to unlock the tower latch, and the protective cover will open.

Removable fan cover for cleaning

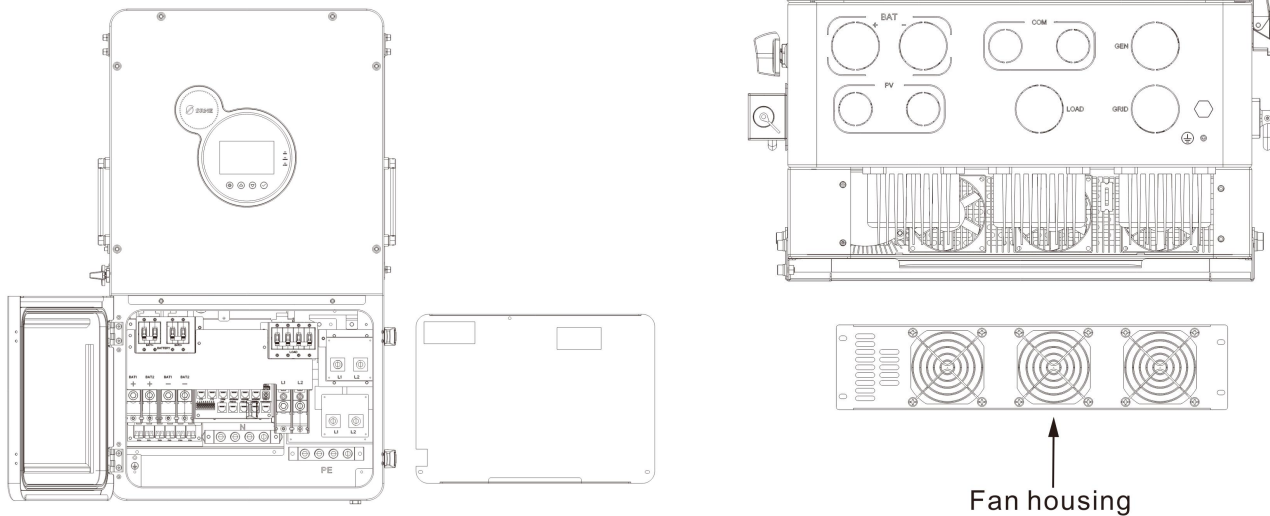

#### NOTICE

When using the device in areas with poor air quality, the dust screen is easily blocked by air particles. Please disassemble and clean the dust screen periodically to avoid affecting the internal air flow rate of the inverter, which may trigger an over-temperature protection fault (19/20 fault) affecting the use of the power supply and the service life of the inverter.

## 4. Connection Instructions

### 4.1 Split-phase Mode

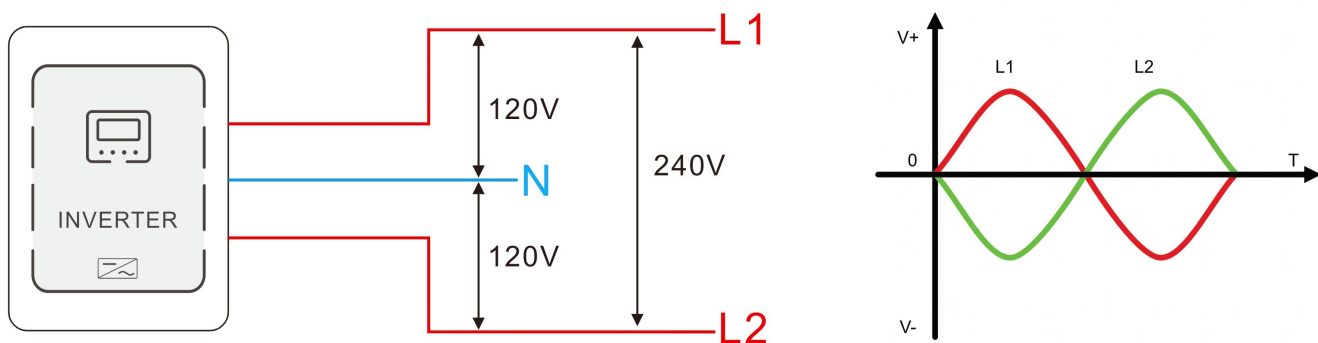

Project	Description
AC output phase voltage (L1-N, L2-N)	90~140Vac, 120Vac default
AC output line voltage (L1-L2)	180~280Vac, 240Vac default

#### NOTICE

- Users can change the output voltage through the settings menu. For details, refer to Chapter 5.2.
- The output voltage corresponds to the parameter setting item **【Work Mode Setup】 - 【Output Phase Voltage】**, and the output phase voltage can be set within the range of 100V to 133V.

## 4.2 Cable & Circuit Breaker Selection

### ■ PV

Models	Cable Diameter	Max. Input Current	Circuit Breaker Specifications
HEBP48150U320-H	6mm <sup>2</sup> /10AWG	42A	2P-50A
HEBP48160U340-H	6mm <sup>2</sup> /10AWG	42A	2P-50A
HEBP48180U380-H	6mm <sup>2</sup> /10AWG	42A	2P-50A

### ■ Battery

Models	Cable Diameter	Max. Input Current	Circuit Breaker Specifications
HEBP48150U320-H	70mm <sup>2</sup> / 00 AWG	160*2A	2P-200A / Dual Circuits
HEBP48160U340-H	85mm <sup>2</sup> /000AWG	170*2A	2P-200A / Dual Circuits
HEBP48180U380-H	85mm <sup>2</sup> /000AWG	190*2A	2P-200A / Dual Circuits

### ■ Grid

Models	Output Mode	Cable Diameter	Max. Input Current	Circuit Breaker Specifications
HEBP48150U320-H	Split-phase	85mm <sup>2</sup> /000AWG(L1/L2/N)	200A	3P-250A
HEBP48160U340-H	Split-phase	85mm <sup>2</sup> /000AWG(L1/L2/N)	200A	3P-250A
HEBP48180U380-H	Split-phase	85mm <sup>2</sup> /000AWG(L1/L2/N)	200A	3P-250A

### ■ Generator

Models	Output Mode	Cable Diameter	Max. Input Current	Circuit Breaker Specifications
HEBP48150U320-H	Split-phase	35mm <sup>2</sup> /2AWG(L1/L2/N)	80A	3P-100A
HEBP48160U340-H	Split-phase	35mm <sup>2</sup> /2AWG(L1/L2/N)	80A	3P-100A
HEBP48180U380-H	Split-phase	35mm <sup>2</sup> /2AWG(L1/L2/N)	80A	3P-100A

### ■ Load

Models	Output Mode	Cable Diameter	Max. Output Current	Circuit Breaker Specifications
HEBP48150U320-H	Split-phase	85mm <sup>2</sup> /000AWG(L1/L2/N)	200A	3P-250A
HEBP48160U340-H	Split-phase	85mm <sup>2</sup> /000AWG(L1/L2/N)	200A	3P-250A
HEBP48180U380-H	Split-phase	85mm <sup>2</sup> /000AWG(L1/L2/N)	200A	3P-250A

#### NOTICE

#### ● PV input:

- ① Use a stripper to remove the 6-8mm (0.24~0.31 in) insulation of the cable.
- ② Fixing the ferrule at the end of the cable (ferrule needs to be prepared by the user).

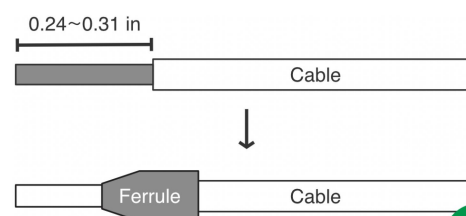

### ● AC input & AC output & Generator:

Use a stripper to remove the 20mm (0.79 in) insulation of the cable.

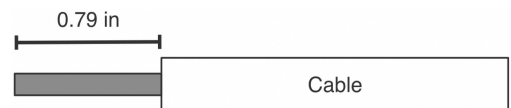

### ● Battery:

① Use a stripper to remove the 20mm (0.79 in) insulation of the cable.

② Fix the cable lug provided with the package at the cable end.

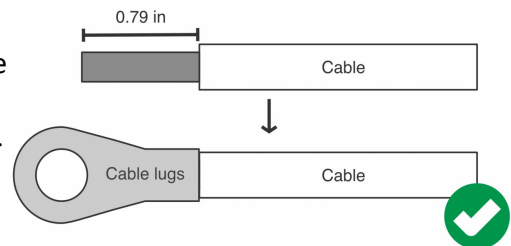

Wire diameter specifications are for reference only. For longer distances between the PV array and inverter, or between the inverter and batteries, use thicker wires to reduce voltage drop and improve system performance.

## 4.3 Grid & Load & Generator Connection

Connect the live, neutral and ground cables in the position and order of the cables as shown in the diagram below.

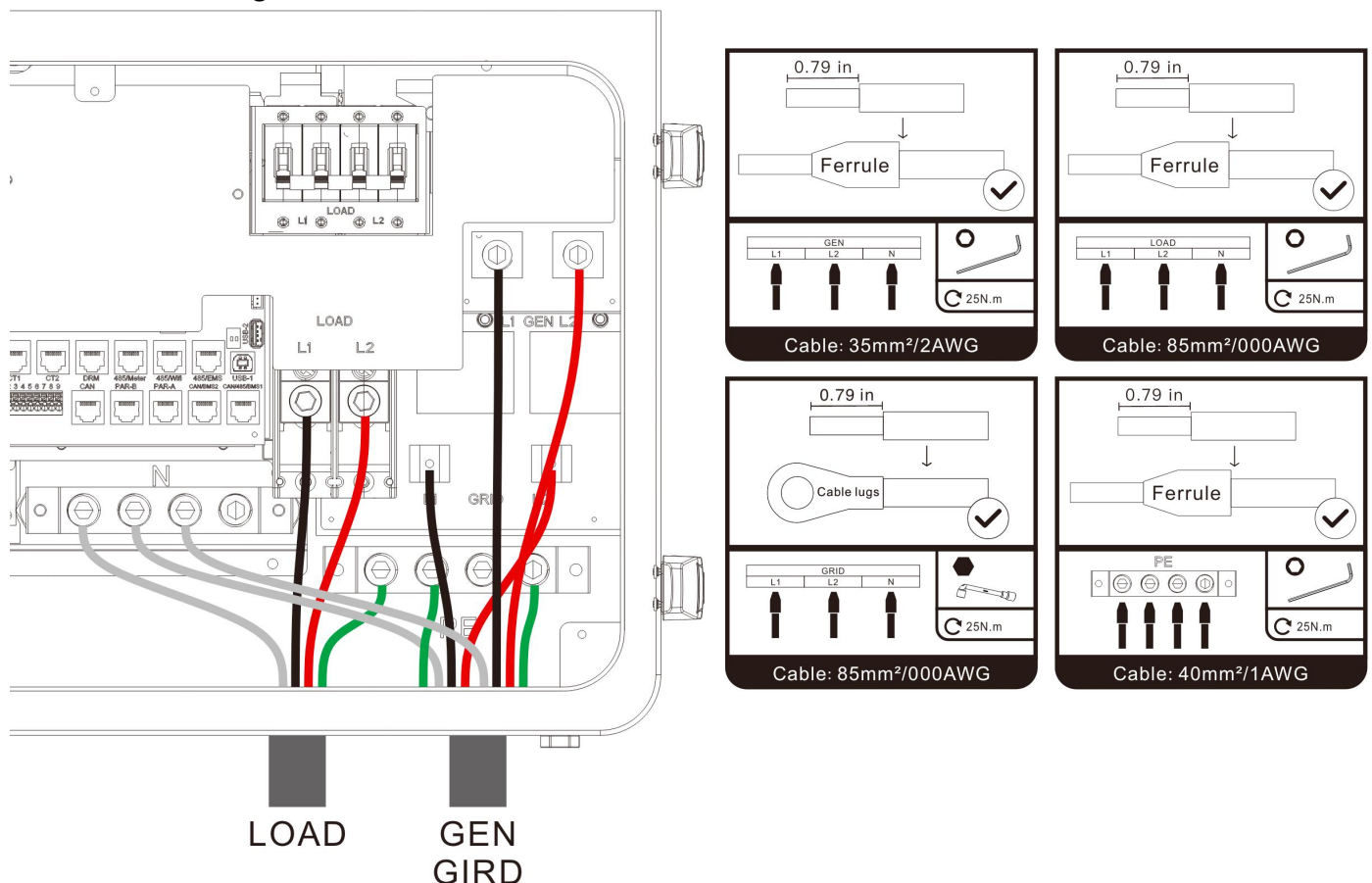

### DANGER

- Before connecting AC input and output, the circuit breaker must be turned off to avoid electric shock hazards, and never operate with electricity.
- Please check that the cable used is sufficient for the requirements, too thin, poor quality cables are a serious safety hazard.

## 4.4 Battery Connection

Connect the positive and negative cable of the battery according to the diagram below.

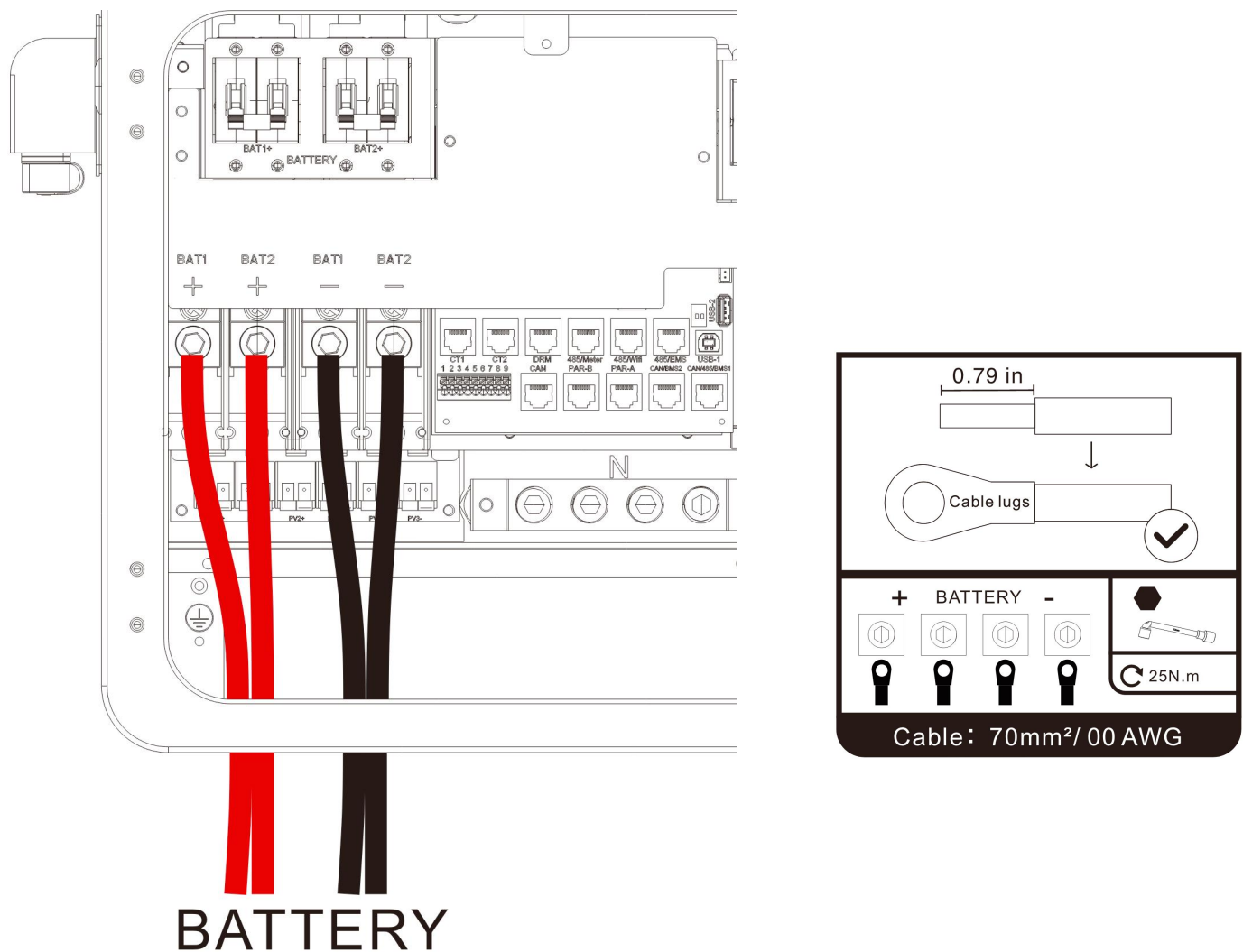

### DANGER

- Before connecting the battery, the circuit breaker must be turned off to avoid electric shock hazards, and never operate with electricity.
- Confirm the positive and negative poles of the battery according to the markings to ensure correct connection, avoiding inverter damage caused by reverse polarity.
- Verify the cable specifications and parameters, and select cables that meet the rated current and voltage transmission requirements of the equipment. Cables with too small diameter or substandard insulation shall be forbidden.
- The connection cables from the two battery sets to the inverter should be kept as consistent in length as possible to avoid uneven current distribution caused by line impedance differences, which may affect the overall system performance.

## 4.5 PV Connection

Connect the positive and negative cables of the three PV circuits according to the diagram below.

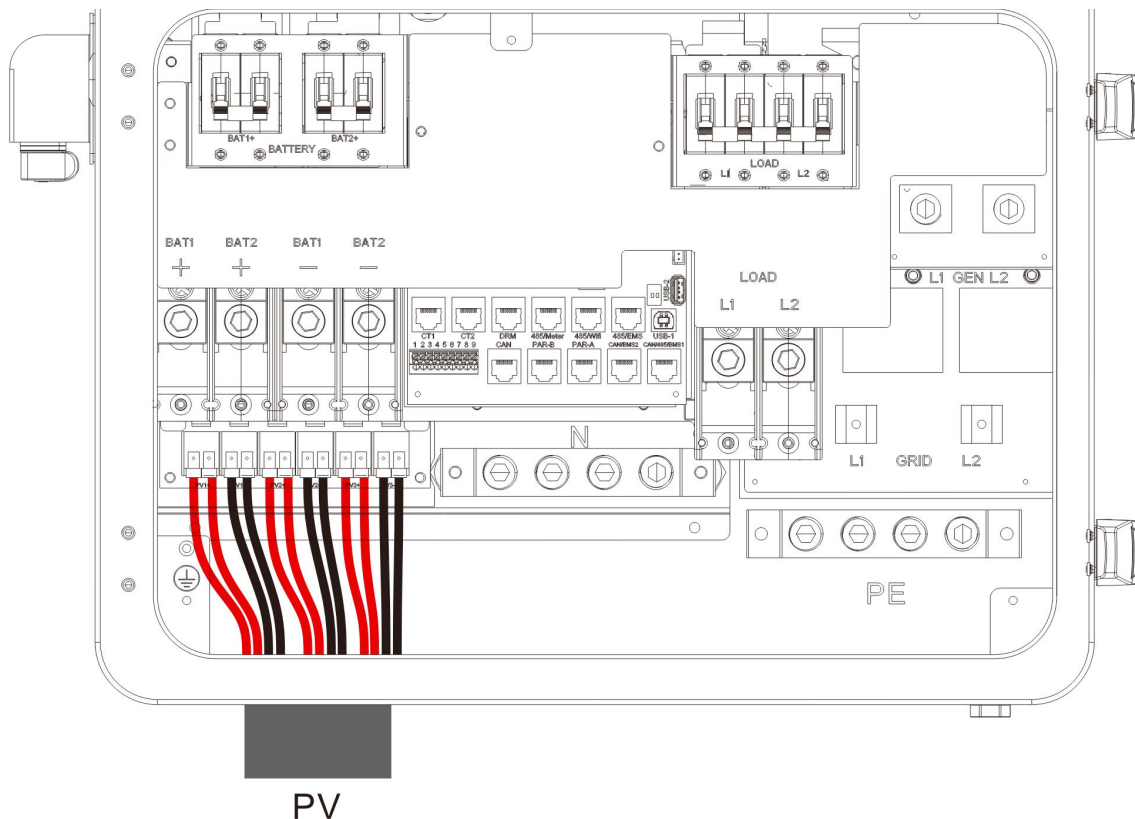

### DANGER

- Before connecting the PV, the circuit breaker must be turned off to avoid electric shock hazards, and never operate with electricity.
- Make sure that the open-circuit voltage of the PV modules connected in series does not exceed the max. open-circuit voltage of the inverter (the value is 600V), otherwise the inverter may be damaged.

## Transmitter-PLC Device

The inverter includes a rapid shutdown system that complies with 2017 and 2020 NEC 690.12 requirements. A rapid shutdown switch should be connected to the RSD terminals on the inverter and mounted on a readily accessible location outdoors (check with your AHJ for requirements).

The APsmart Rapid Shutdown System Transmitter-PLC is part of a rapid shutdown solution when paired with APsmart RSD, a PV module rapid shutdown unit. While powered on, the Transmitter-PLC sends a signal to the RSD units to keep their PV modules connected and supplying energy. RSD units automatically enter rapid shutdown mode when the Transmitter-PLC is switched off and resume energy production when power is restored to the Transmitter-PLC.

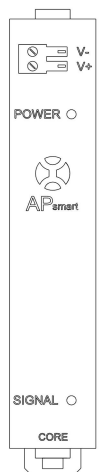

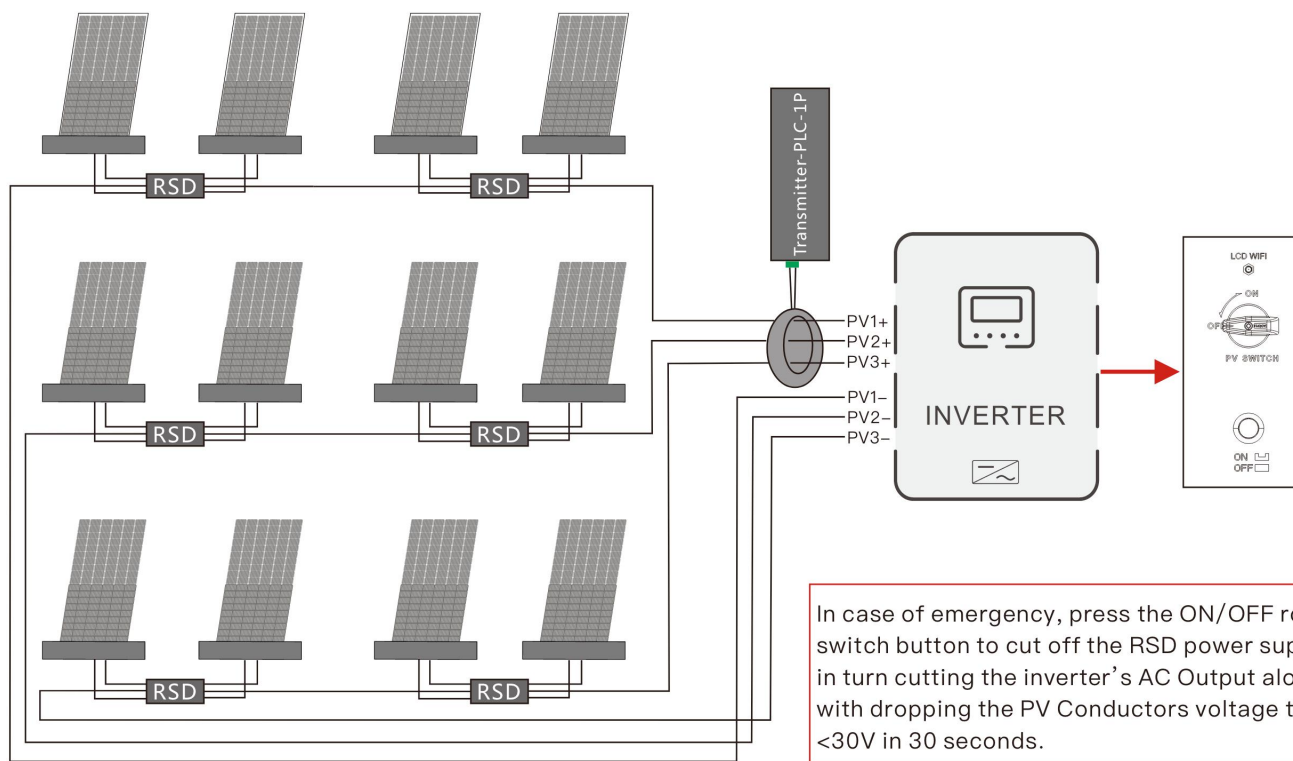

## 4.6 Dry Contact Connection

Use a small screwdriver to push backward in the direction of the arrow, and insert the communication cable into the dry contact port.

Communication cable diameter:  $0.2 \sim 1.5\text{mm}^2$

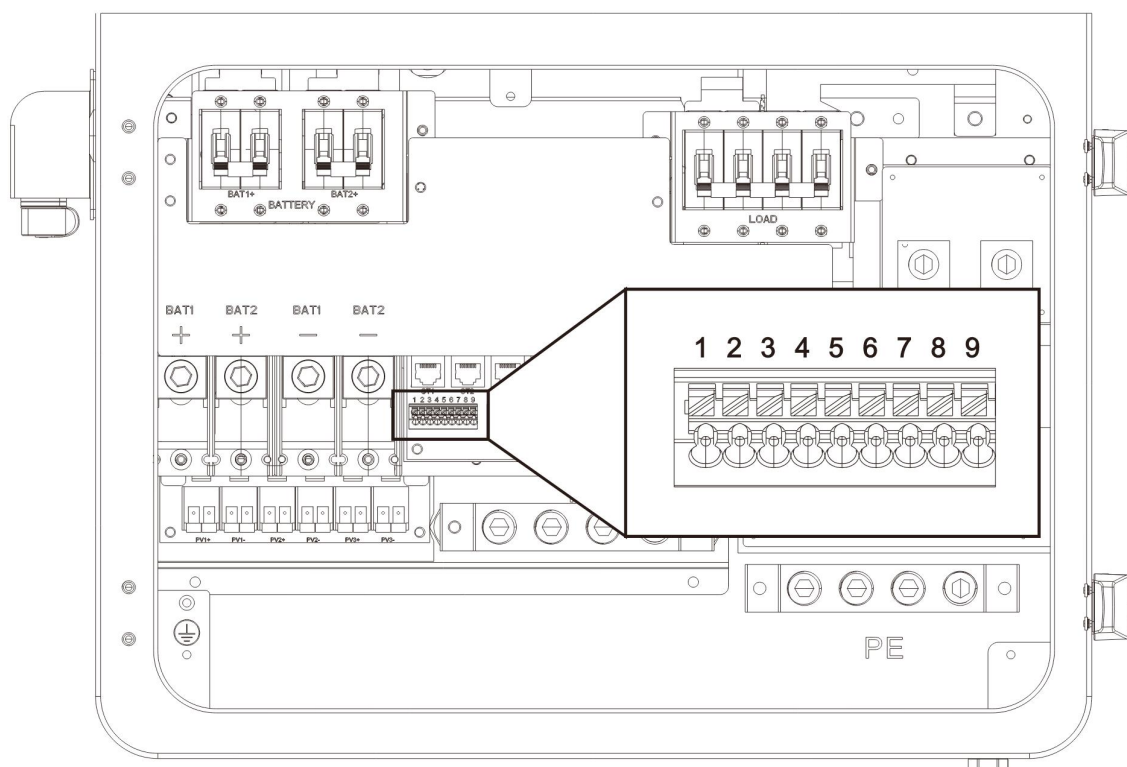

## 4.7 Grounding Connection

Please make sure the grounding terminal connect to the Grounding Bar.

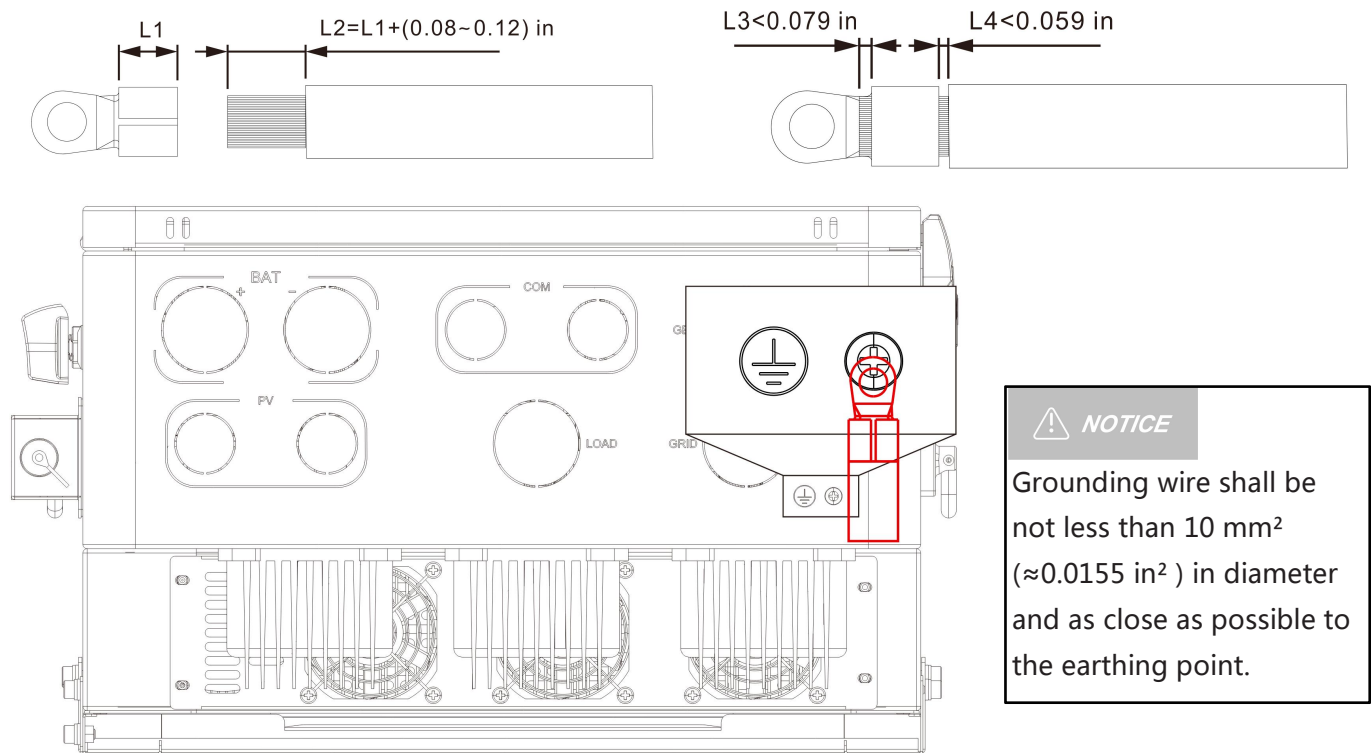

## 4.8 Inverter Start

After ensuring that the wiring is reliable and the wire sequence is correct, restore the terminal protection cover to its original position.

- **Step 1:** Close the circuit breaker of the battery.
- **Step 2:** Press the ON/OFF switch on the side of the inverter. The screen and indicator lights turning on indicates that the inverter has been activated.
- **Step 3:** Sequential close of the circuit breakers for PV, AC input and AC output.
- **Step 4:** Start the loads one by one in order of power from small to large.

## 4.9 Parallel Connection

### 4.9.1 Parallel Operation

1. Up to 9 units connected in parallel.
2. When using the parallel operation function, the following connecting lines (package accessories) shall be firmly and reliably connected.

**Parallel Communication Cable \* 1**

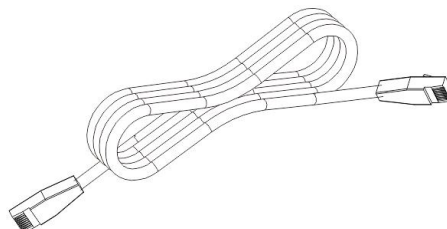

## 4.9.2 Precautions for Connecting Parallel Connection Cables

### 1. Photovoltaic connection:

When connecting in parallel, the PV arrays connected to each inverter must be independent of each other. The PV arrays corresponding to PV1, PV2, and PV3 ports of the same inverter must also be independent.

### 2. Battery connection:

In parallel operations, all inverters must be connected to the same battery bank. Connect BAT+ to BAT+ and BAT- to BAT-. Before powering on the system, thoroughly check the wiring configuration to ensure correctness. Confirm that the wiring lengths between each inverter and the battery are consistent, and verify that the cable size meets the system's current transmission requirements. Incorrect connections may cause abnormal operation of the parallel system.

### 3. Load connection:

In parallel operations, all inverters must be connected with N to N and PE to PE. The AC output L lines of the same phase should be connected together. The wiring method is the same when using a generator as a Smart Load.

### 4. Grid connection:

In parallel operations, all inverters must be connected with N to N and PE to PE. The grid L lines of the same phase should be connected together. The wiring method is identical when using a generator as an input source or for micro-inverters.

### 5. Communication Lines:

Our parallel communication cable is a shielded 8-pin network cable suitable for both single-phase and three-phase parallel connections. Each unit must have one input and one output connection. In a parallel system, the "Parallel A" interface of this machine must be connected to the "Parallel B" interface of the target machine. It is strictly prohibited to connect the "Parallel A" interface of this machine to either the "Parallel B" interface of the same machine or the "Parallel A" interface of the target machine. Additionally, secure each unit's parallel communication cable firmly to the 8-pin network connector to prevent disconnections or poor contacts, which may lead to abnormal system operation or damage to the output.

6. Before and after connecting the system, carefully refer to the system wiring diagram below. Ensure all connections are correct and secure before powering on.

7. After the system is correctly wired, powered on, and operating normally, if a new inverter needs to be connected, ensure that the battery input, PV input, AC input, and AC output are disconnected, and all inverters are powered off before reconnecting to the system.

### 4.9.3 Schematic of Split-phase Parallel Operation

Each inverter's parallel mode must be set to "Split-phase Parallel Mode". The parallel connection diagram is shown below (multiply the number of units accordingly):

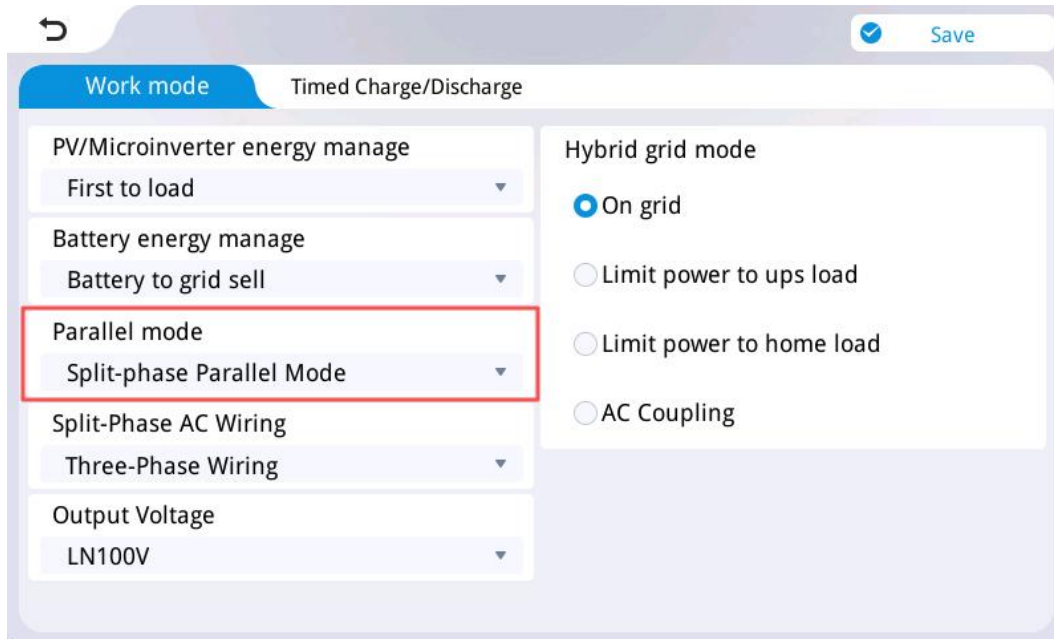

**a) Two units connected in parallel:**

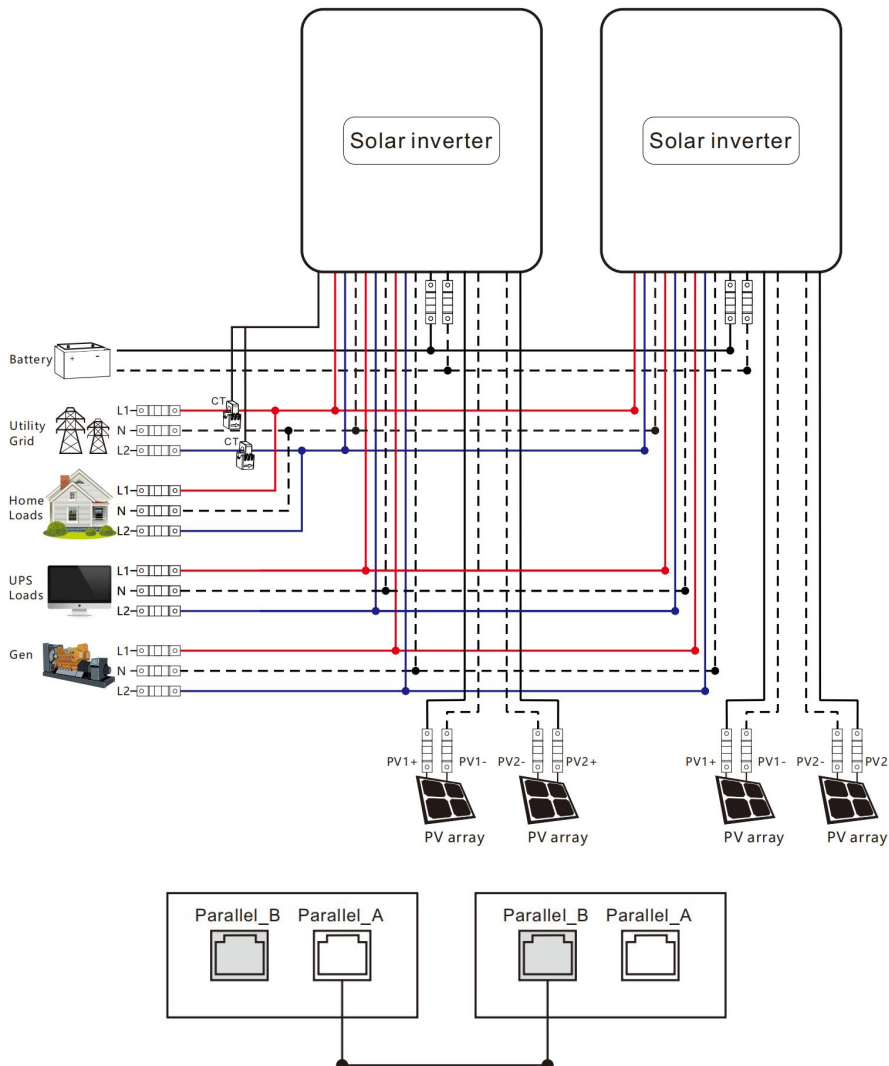

### b) Three units connected in parallel:

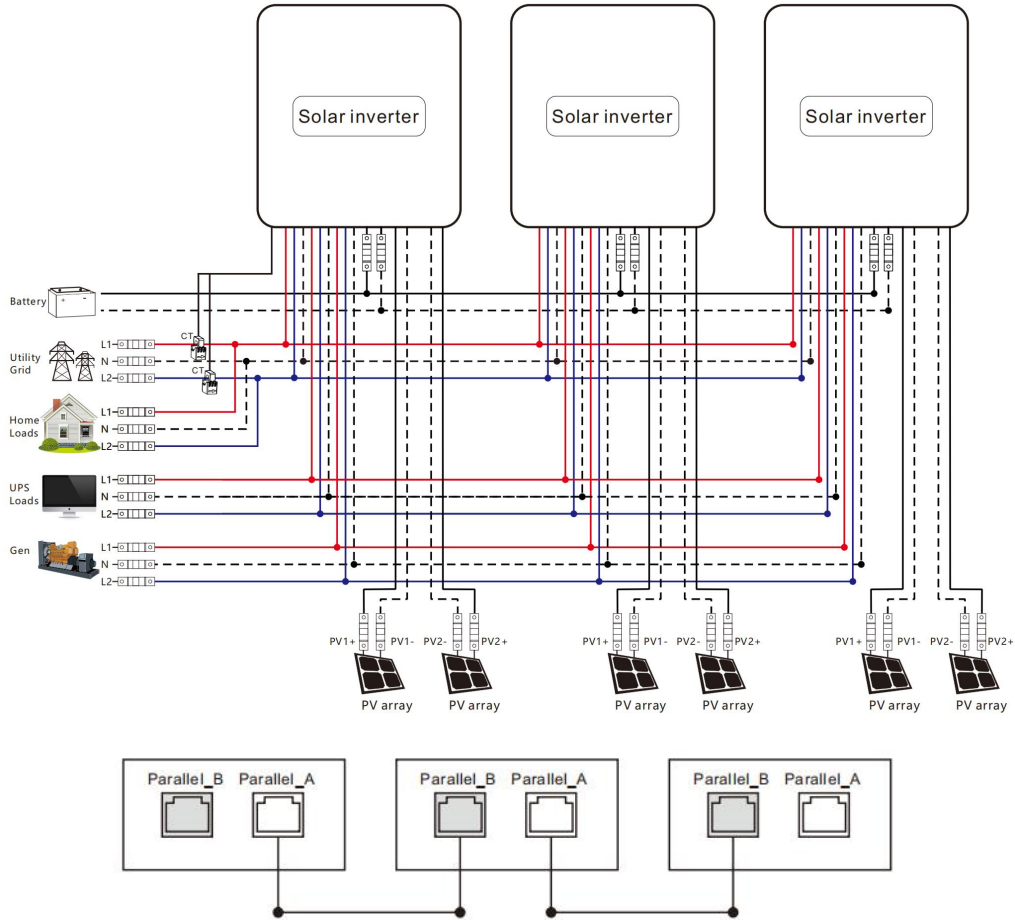

### c) Multiple units connected in parallel:

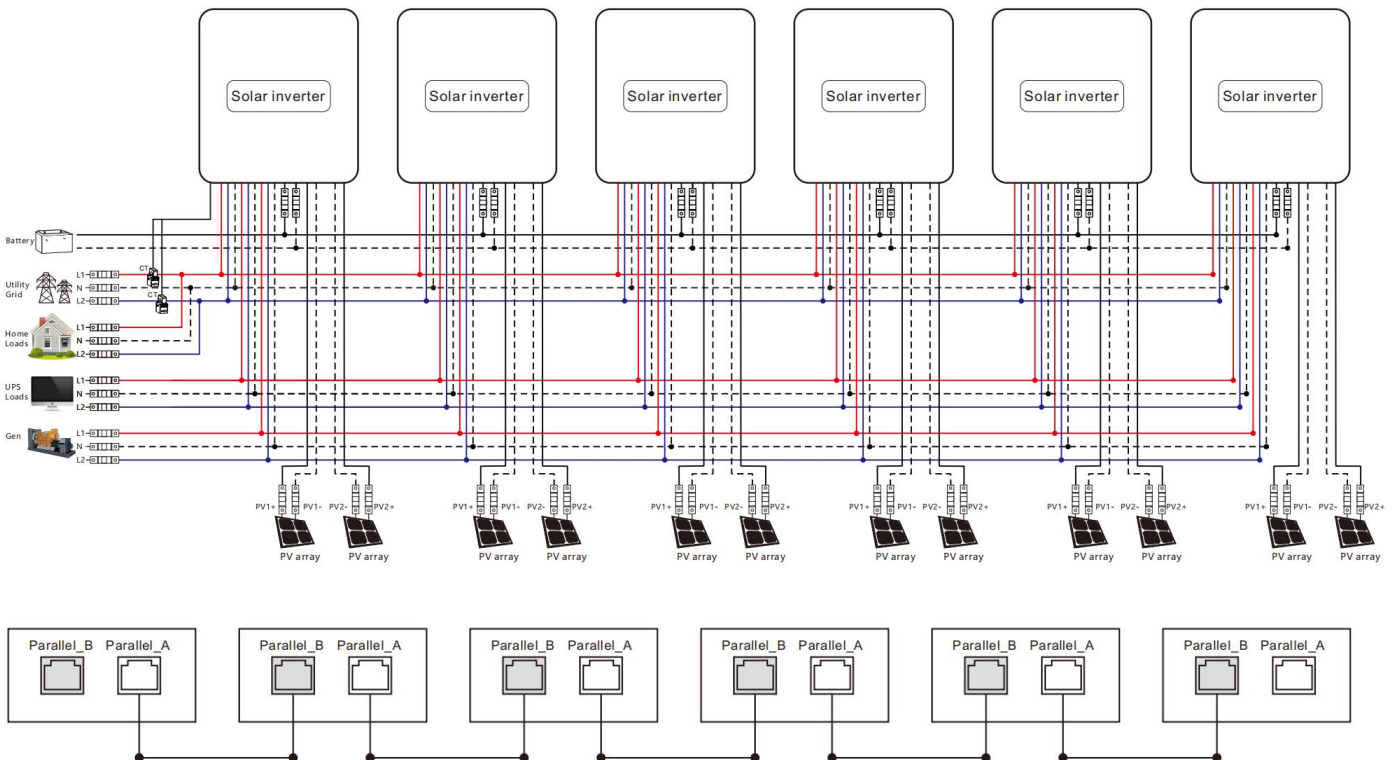

### 4.9.4 Schematic of Three-phase Parallel Operation

Ensure the parallel communication cables of the inverters are securely clamped with no loose connections.

When multiple inverters operate in parallel, refer to the following schematic diagram:

**Parallel Operation in three phase :**  
**Two devices form a three-phase system.**  
**1+1 system:**

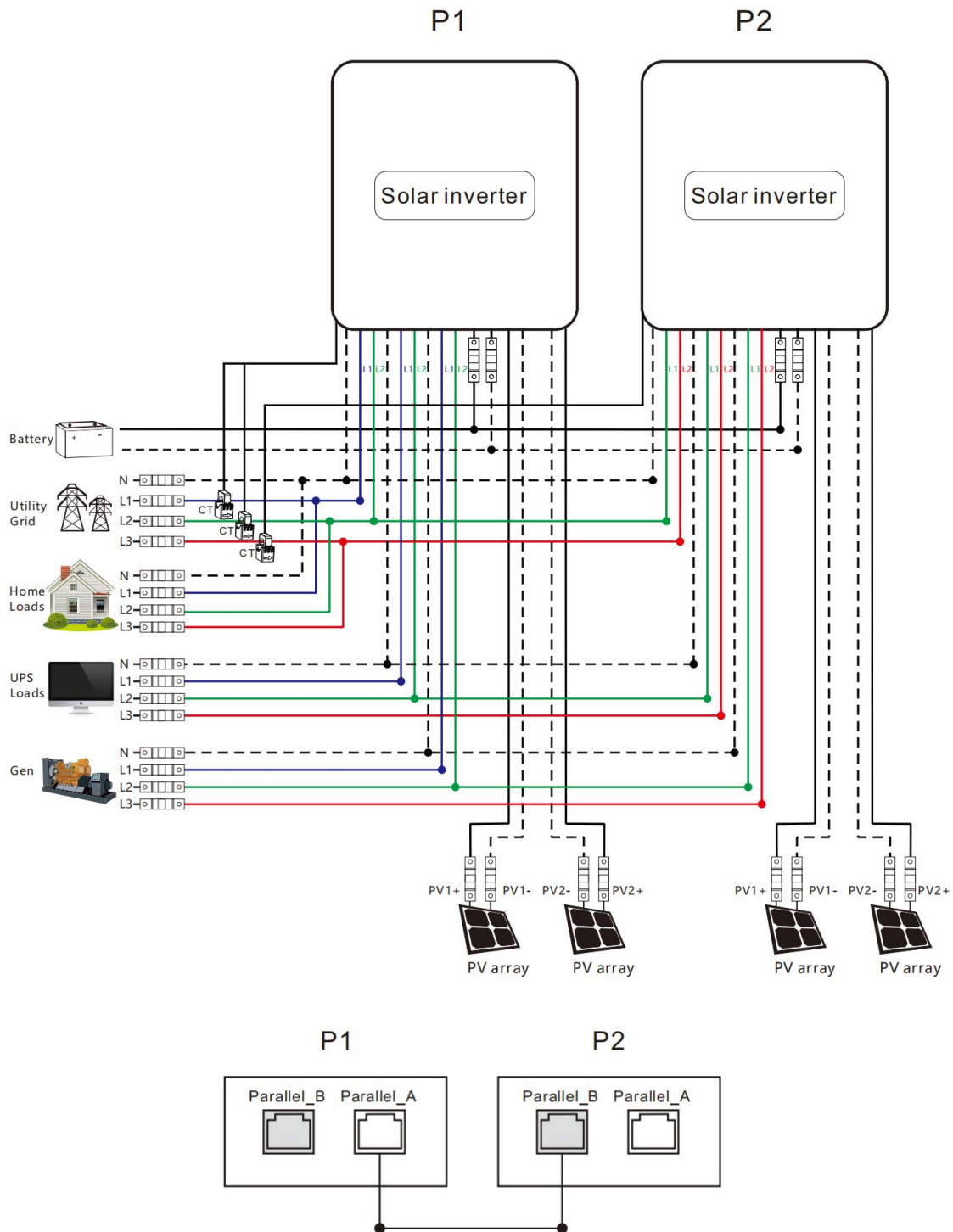

**1+1+1 system:**

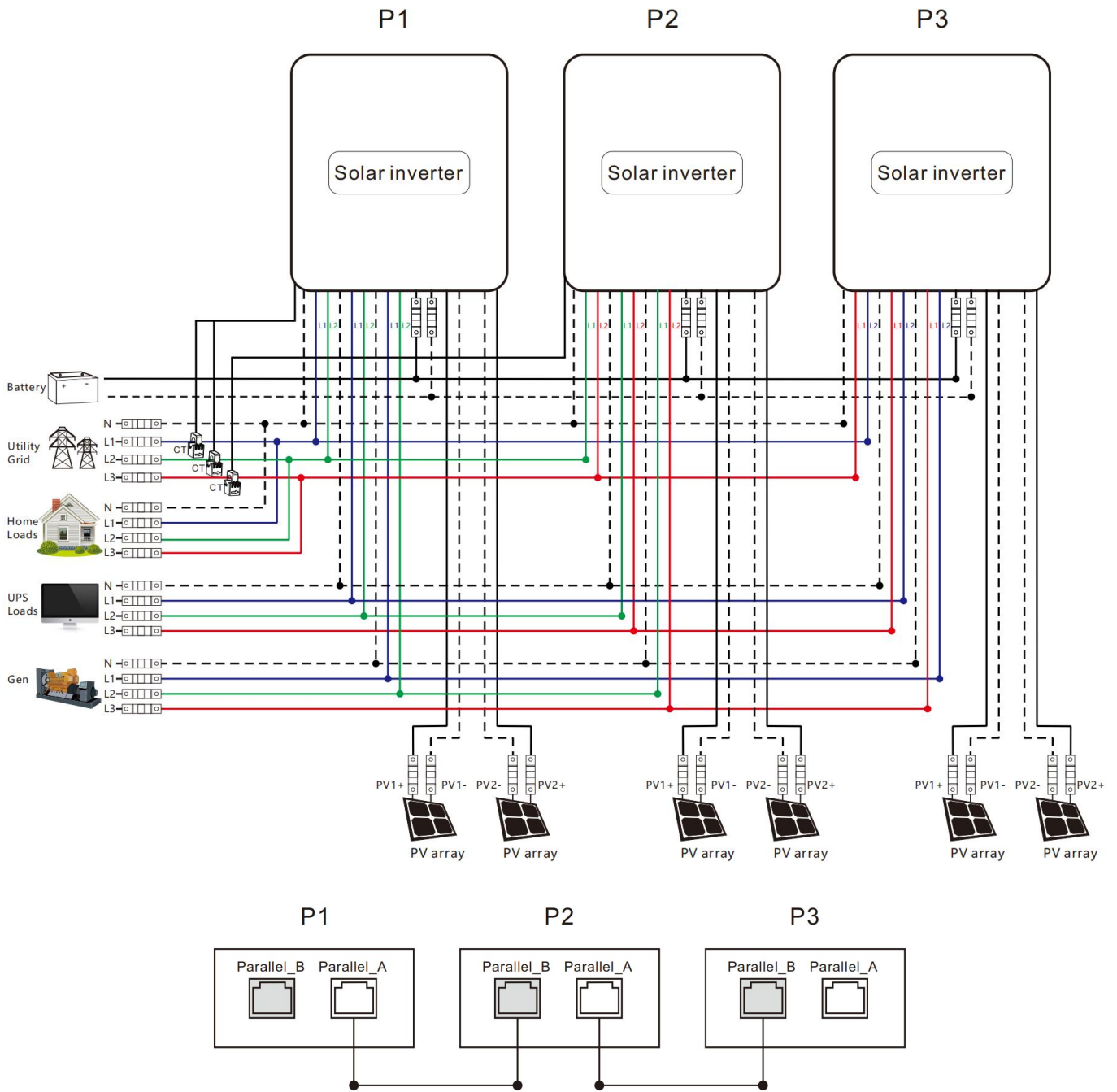

**2+2+2 system:**

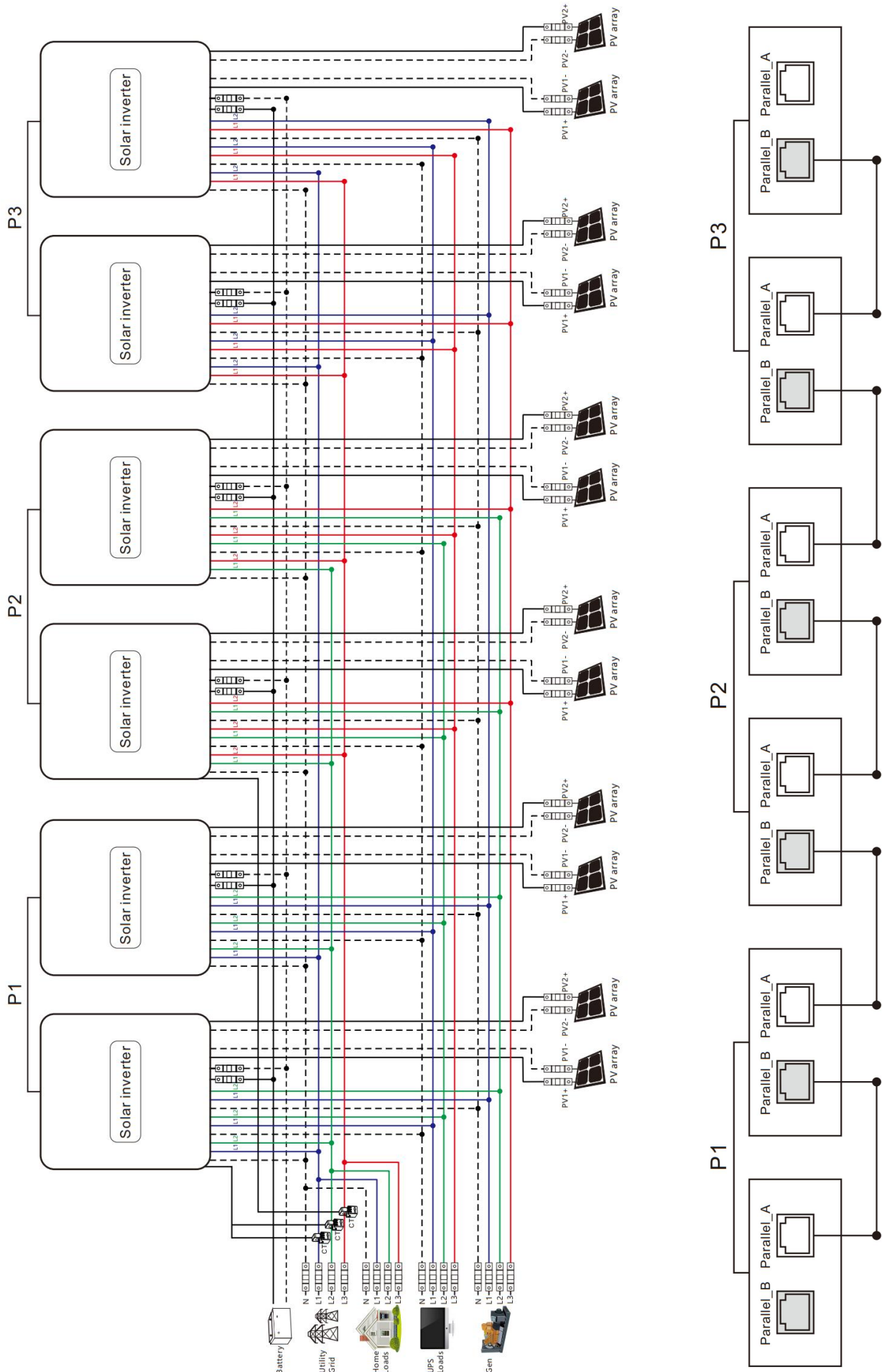

**Notice:**

- 1) Before starting up and running, please check whether the connection was correct to avoid any abnormalities in the system.
- 2) All wiring must be fixed and reliable to avoid wire drop during use.
- 3) When the AC output is wired to the load, it shall be properly wired according to the requirements of the electrical load equipment to avoid damage to the load equipment.
- 4) Settings **【Parallel Mode】** need to be set consistently or only for the host. When the machine is running, the voltage set by the host shall prevail, and the master will force the rewrite of the other slave machines to keep the same set. Only can be set in the standby mode.
- 5) Machine factory default for single machine mode, if you use parallel, split-phase or three-phase function, you need to set the **【Parallel Mode】** item parameters through the screen. The setting method is: Each time the system powers up, one machine starts while the others remain off. Then, based on the on-site system operation mode, set the **【Work Mode Setup】** to **【Parallel Mode】** . After this machine is set successfully, turn off the machine switch and wait for the machine to be powered down, then set the rest of the machines in turn until all machines are set, and then all machines are powered up again at the same time and enter the working state.
- 6) **【Parallel Mode】** Parameter Settings Guide:  
When using single-phase parallel operation, set to "Single-Phase Parallel Connection" .  
When using the three-phase parallel operation function, the following settings are required:  
All machine screens connected to P1 must be set to "Three-Phase Parallel A" ;  
All machine screens connected to P2 must be set to "Three-Phase Parallel B" ;  
All machine screens connected to P3 must be set to "Three-Phase Parallel C" .  
At this point, the voltage phases between P1-P2, P1-P3, and P2-P3 differ by 120 degrees.
- 7) After the system runs, the output voltage is measured correctly, and then the load setting is connected.
- 8) For other three-phase parallel connection configurations, such as: 1+1+2; 1+2+3; 2+2+1; 3+1+1; 4+1+1 systems, please contact the manufacturer for technical support.
- 9) When operating in parallel, inverters shall be installed in accordance with the proximity principle to avoid communication abnormalities caused by excessively long communication lines. If the line length is unavoidable, additional network cables can be used for end-to-end connection to optimize the communication loop.

# 5. Operation

## 5.1 Operation and Display Panel

The inverter's operation and display panel includes 1 LCD screen, 3 LED indicators, and 4 Operation buttons.

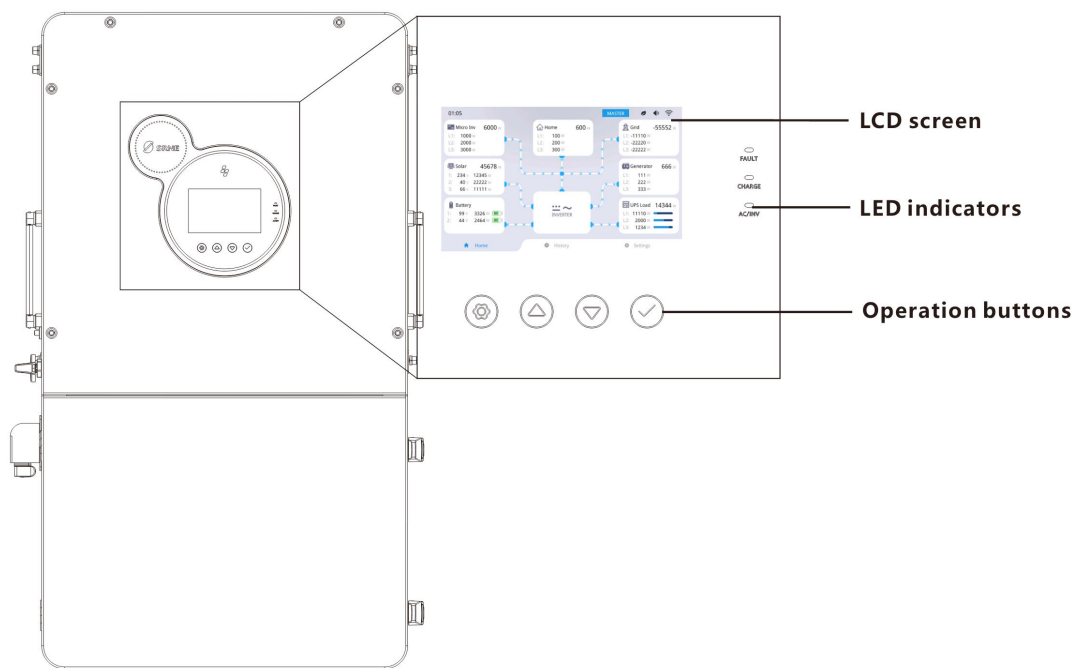

### ■ Operation buttons

Button	Description
	To enter/exit the setting menu
	To last selection
	To next selection
	To confirm/enter the selection in setting menu

### ■ LED indicators

Indicator	Color	Description
FAULT	Red	Flashing: Error occurred, Primary Fault
		Steady on: Error occurred, Secondary Fault
		Not lit: Error occurred, Level 3 or Level 4 fault
CHARGE	Green	Continued: Charging completed
		Flashing: Charging in progress
AC/INV	Yellow	Continued: Utility grid bypass output
		Flashing: Inverter output

## ■ Display panel

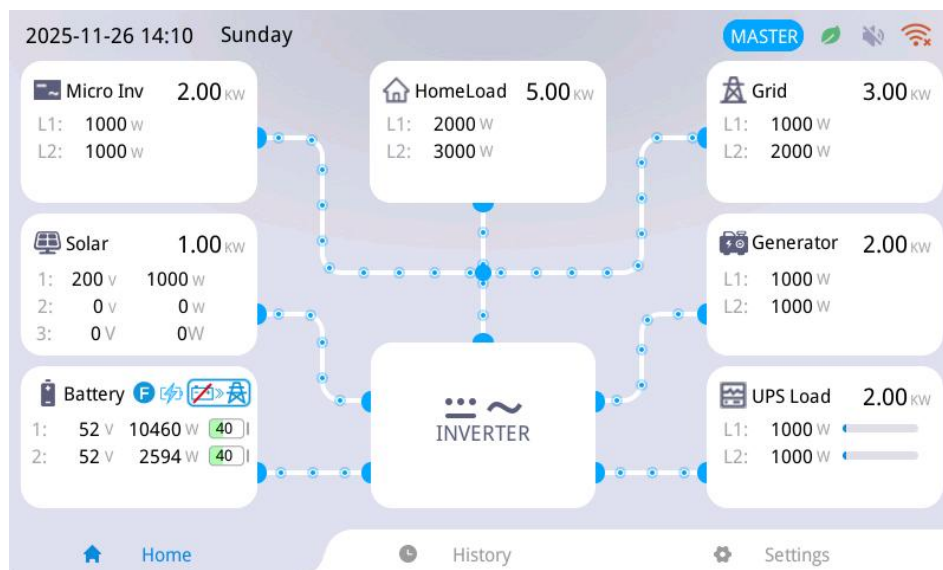

Icon	Description	Icon	Description
	Microinverter		Grid
	Solar Panel		Generator
	Battery		UPS Load
	Household Load		Inverter
	Home Page		Energy Saving Mode
	Historical Data		Settings
01 : 05	Local Time		Buzzer
	WiFi Status		Energy Flow
MASTER	Main Unit Logo		

## ■ View real-time data

On the LCD home screen, click the inverter icon, battery icon, utility grid icon, generator icon, UPS load icon, or PV icon allows viewing of real-time data for each component. The microinverter and household load icons are non-clickable, as their data is fully displayed on the home page.

System Data			
NO.	Real-Time Data Item	NO.	Real-Time Data Item
1	MCU1 Version	12	SN Code (Inverter Serial Number)
2	MCU2 Version	13	Machine Status
3	Minor Version Number	14	DC/DC Temperature
4	LCD Version	15	DC/AC Temperature
5	Rated Power	16	Transformer Temperature

6	Customer ID	17	External Battery Temperature
7	RS485 Address	18	Parallel Total Local Load Power
8	Bus Positive Voltage	19	Parallel Total Household Load Power
9	Bus Negative Voltage	20	Parallel Total Grid Power
10	Bus Total Voltage	21	Parallel Total Generator Power
11	Slave CPU		
<b>Battery Data</b>			
1	Battery 1 Voltage	7	Battery 2 Voltage
2	Battery 1 Charge/Discharge Power	8	Battery 2 Charge/Discharge Power
3	Battery 1 Charge/Discharge Current	9	Battery 2 Charge/Discharge Current
4	Battery 1 SOC (%)	10	Battery 2 SOC (%)
5	Battery Type	11	BMS Communication Protocol
6	Charging Status	12	BMS Data
<b>Grid Data</b>			
1	L1 Voltage	7	L2 Voltage
2	L1 Current	8	L2 Current
3	L1 Active Power	9	L2 Active Power
4	L1 Apparent Power	10	L2 Apparent Power
5	L1 CT Power	11	L2 CT Power
6	Frequency	12	Utility Charging Current
<b>UPS Load Data</b>			
1	L1 Voltage	7	L2 Voltage
2	L1 Current	8	L2 Current
3	L1 Active Power	9	L2 Active Power
4	L1 Apparent Power	10	L2 Apparent Power
5	L1 Load Rate	11	L2 Load Rate
6	Overall Load Rate	12	Frequency
<b>PV Panel Data</b>			
1	Solar1 Voltage V	6	Solar2 Power W
2	Solar1 Current A	7	Solar3 Voltage V
3	Solar1 Power W	8	Solar3 Current A
4	Solar2 Voltage V	9	Solar3 Power W
5	Solar2 Current A	10	PV Total Power
<b>Generator Data</b>			
1	L1 Voltage	6	L2 Voltage
2	L1 Current	7	L2 Current
3	L1 Active Power	8	L2 Active Power

4	L1 Apparent Power	9	L2 Apparent Power
5	Frequency	10	Grid Charging Current
<b>Home Load Data</b>			
1	L1 Voltage	5	L2 Voltage
2	L1 Current	6	L2 Current
3	L1 Active Power	7	L2 Active Power
4	L1 Apparent Power	8	Frequency

## ■ Browsing Detailed Data with Buttons



1. Press the up/down buttons, and when "HOME" is highlighted in blue, press the confirm button to select the home page icon.

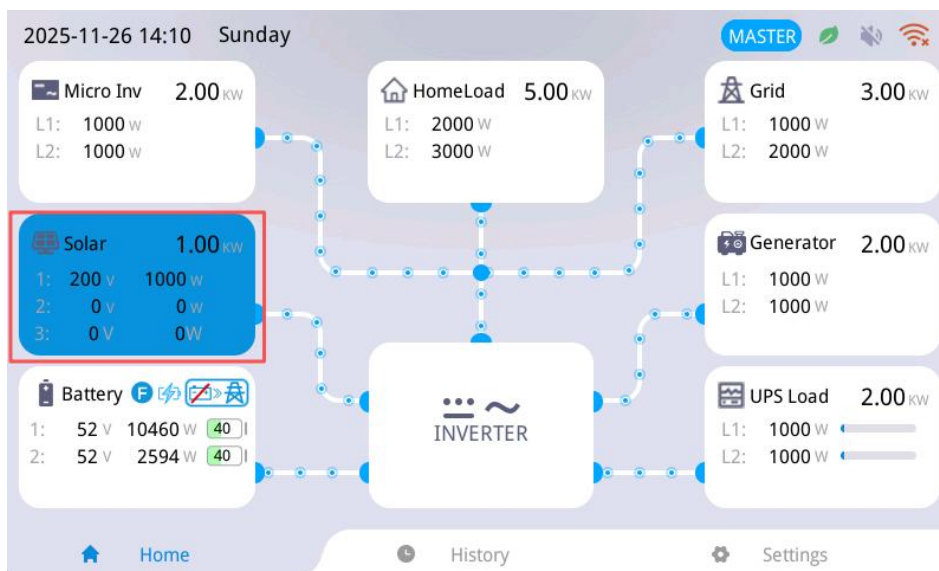

2. After selecting the home page icon, press the confirm button again to enter the data details page.

## 5.2 Setting Parameters

### Operation Instructions:

1. Click the "Settings" button in the bottom menu bar of the screen to enter the settings interface. It includes seven categories: **"Basic setup"**, **"Work mode setup"**, **"Battery setup"**, **"On-Grid setup"**, **"Advance setup"**, **"WiFi setup"**, and **"Firmware Upgrade"**.

2. When modifying settings, if password protection is enabled, you must enter the password to change parameters. The default password is "4321".

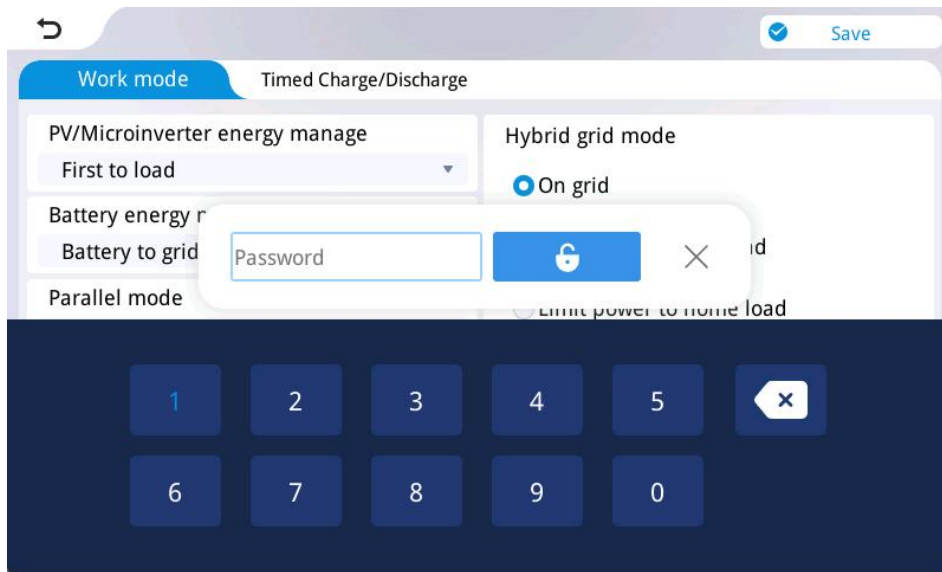

■ Setting flow chart:

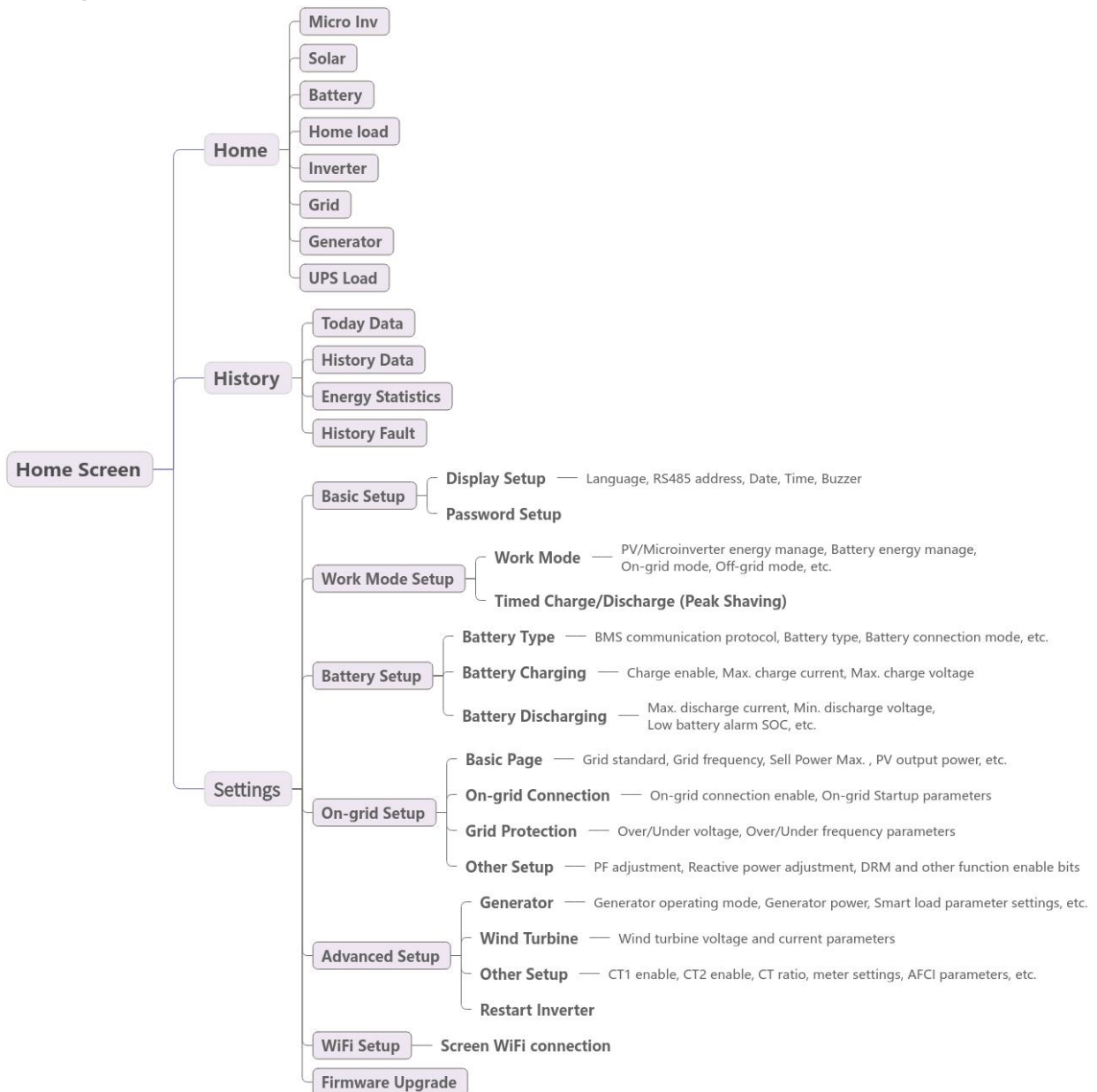

## 5.2.1 Basic Setup

### 5.2.1.1 Display Setting

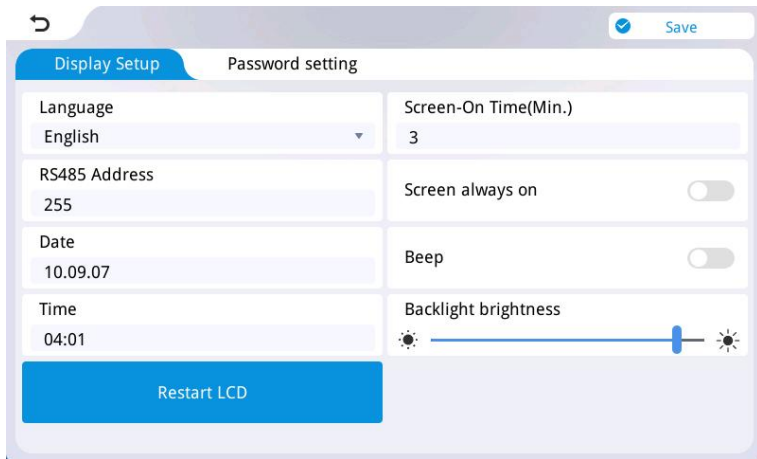

- **Language:** English, Italian, German, Spanish, Chinese.
- **RS485 Address:** RS485 address of the inverter.
  - ① Single device: Adjustable range 1~254.
  - ② Parallel devices: Adjustable range 1~9.
- **Date:** Set year, month, day.
- **Time:** Set hour and minute.
- **Screen-On Time(Min.):** Adjustable range 1~30 minutes.
- **Screen always On:** Select whether the screen stays on continuously.

- **Beep:** Select whether to enable buzzer alarm.
- **Backlight brightness:** Adjustable from 0~100%.
- **Restart LCD:** Restart the Screen

### 5.2.1.2 Password Setting(Change Password)

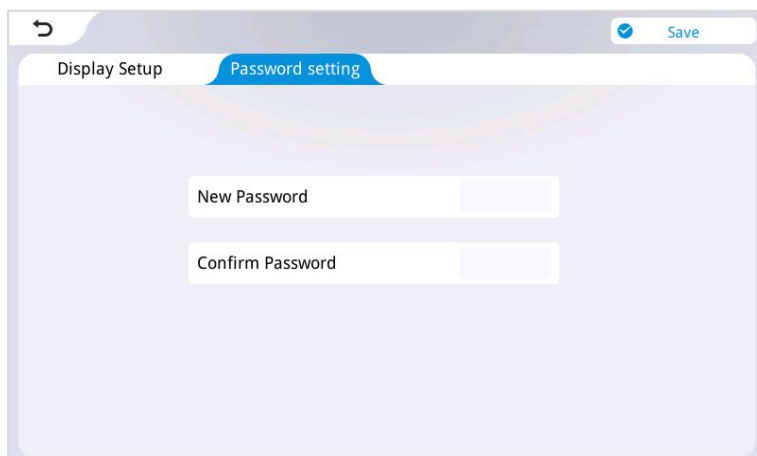

- **New Password:** Enter a custom new password.
- **Confirm Password:** Re-enter exactly the same content as the new password above to verify the accuracy of the password setting.

## 5.2.2 Work Mode Setup

### 5.2.2.1 Work Mode

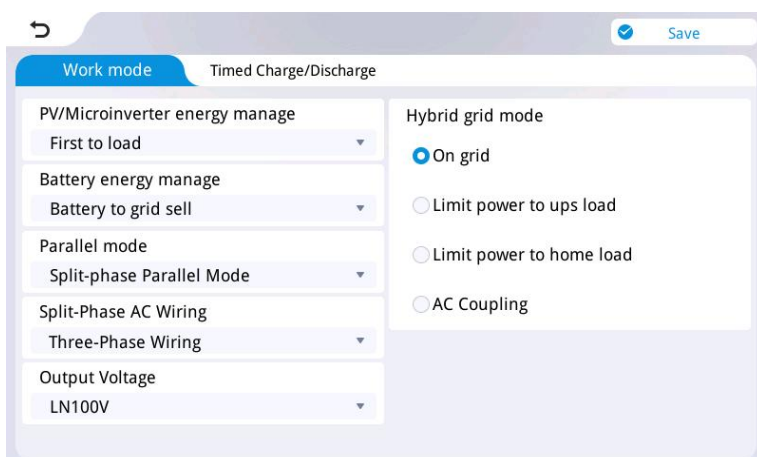

1. **Grid power sales:** on grid output power.
2. **UPS Load:** Connected to the LOAD port of the machine.
3. **Home Load:** Refers to the load connected to the machine's GRID port, which requires external CT or energy meter for use.(Otherwise, the power of the Home load cannot be detected.)
4. **AC Coupling:** Connect the grid-connected inverter to the grid side of the hybrid inverter.

This is the detailed page of "Work Mode"		
Parameter Meaning	Options	Description
Hybrid grid mode	On grid	Direct grid connection of excess PV energy.
	Limit power to UPS load	In this mode, solar or battery energy is only used for UPS load and smart load, Excess energy will not be fed into the grid (UPS load is reverse-flow protected).
	Limit power to home load	In this mode, solar or battery energy is used only for the UPS load, smart load, and home load. Excess energy will not be fed into the grid (HOME load is reverse-flow protected).
	AC Coupling	This mode is used to add AC coupling functionality to on-grid inverters. The on-grid inverter needs to be connected to the grid side of the hybrid inverter (effective only when the GEN port is not set to micro-inverter mode); or connected to the generator side of the hybrid inverter (effective only when the GEN port is set to micro-inverter mode). In this mode, the hybrid inverter will use the grid energy from the on-grid inverter to power loads or charge batteries.
PV/Microinverter energy manage	When the hybrid grid mode is set to "Limit power supply to UPS load" or when CT1 is not connected, the meter is not communicating, or communication fails (effective only when the meter detection location is set to the grid side), the subsequent loads refer to the UPS load and smart load. When the hybrid grid mode is set to "Limit Home Load/Grid Power Supply" and CT1 is successfully connected or the meter communication is successful (effective only when the meter detection location is set to the grid side), the subsequent loads refer to the UPS load, smart load, and home load.	
	First to Load	PV energy priority: load>charge>on grid. Micro-inverter energy priority: load>charge>on grid.
	First to charging	PV energy priority: charge>load>on grid. Micro-inverter energy priority: load>charge>on grid.
	First to grid	PV energy priority: load>on grid>charge. Micro-inverter energy priority: load>on grid>charge.
Battery energy manage	Standby	Battery only discharge in off-grid working mode.
	Battery to UPS load	The battery can supply power to the UPS load, smart load, and home load, but does not participate in selling power to the grid.
	Battery to home load	The battery powers UPS loads, smart loads, and household loads, but does not participate in grid selling.
	Battery to grid sell	The battery can supply power to the UPS load, smart load, and home load, and participate in selling power to the grid.
Parallel mode	Stand-alone.	
	Parallel operation.	
Grid type	When Single-phase Mode is selected, the default voltage between L1 and L2 is 240VAC, where L1 shall be connected to the live wire and L2 to the neutral wire.	
	When Split-phase Mode is selected, the phase voltage of L1 and L2 is 120VAC, the line voltage is 240VAC, and the phase difference between L1 and L2 is 180°.	
	When Three-phase Mode is selected, the phase voltage of L1 and L2 is 120VAC, the line voltage is 208VAC, and the phase difference between L1 and L2 is 120°.	
Output phase voltage	Settable: 100V, 105V, 110V, 115V, 120V, 127V, 133V	

## 5.2.2.2 Peak Shaving

Work mode: Timed Charge/Discharge

Timed charging enable

	Start Time	End Time	Stop SOC	Stop Volt	Max Power	Grid	Gen
1	01:01	02:02	1%	55.0V	444W	<input checked="" type="checkbox"/>	<input checked="" type="checkbox"/>
2	03:03	04:04	2%	22.0V	555W	<input type="checkbox"/>	<input type="checkbox"/>
3	05:05	06:06	3%	33.0V	666W	<input type="checkbox"/>	<input type="checkbox"/>

Timed discharging enable

Max consumption enable

	Start Time	End Time	Stop SOC	Stop Volt	Max Power
1	07:07	08:08	4%	44.0V	111W
2	09:09	10:10	6%	55.0V	222W
3	11:11	12:12	7%	66.0V	333W

Work mode: Timed Charge/Discharge

Monday enable	<input checked="" type="checkbox"/>	Tuesday enable	<input type="checkbox"/>
Wednesday enable	<input checked="" type="checkbox"/>	Thursday enable	<input type="checkbox"/>
Friday enable	<input type="checkbox"/>	Saturday enable	<input checked="" type="checkbox"/>
Sunday enable	<input checked="" type="checkbox"/>		

- **Timed charging enable:** Select whether to enable scheduled charging.
- **Timed discharging enable:** Select whether to enable scheduled discharging.
- **Start/End Time:** Set the time period for scheduled charging/discharging.
- **Stop SOC:** Set the battery's cutoff SOC values for charging/discharging during the scheduled charging/discharging time periods. (effective when BMS communication is successful).
- **Stop Volt:** Set the battery's cutoff voltage values for charging /discharging during the scheduled charging/ discharging time periods. (effective when BMS communication is not established or fails).
- **Max. Power:** Setting the battery charging power and discharging power during the scheduled charging and discharging time period.
- **Grid:** Allow the grid to charge the battery during the scheduled charging period.
- **Gen:** Allow the generator to charge the battery during the scheduled charging period.

- **Max. consumption enable:** Allow the battery to discharge outside the scheduled discharging period.
- **Weekly Enable:** Set the days of the week for scheduled charging/discharging (only valid for scheduled charging/discharging).

## 5.2.3 Battery Setup

### 5.2.3.1 Battery Type

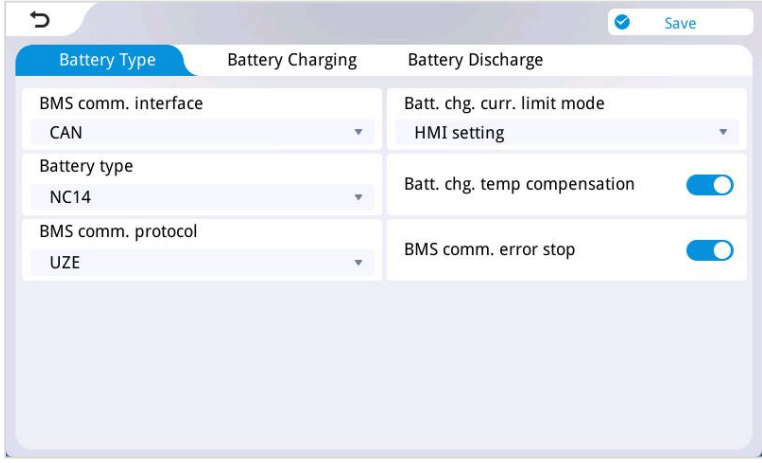

- **BMS comm. interface:**

- ① **Disable:** BMS communication disabled.
- ② **RS485:** BMS RS485 communication.
- ③ **CAN:** BMS CAN communication.

- **Battery Type:**

- ① **USER define:** All battery parameters can be customized by the user.
- ② **SLd:** Sealed Lead-acid Battery.
- ③ **FLd:** Flooded Lead-acid Battery.
- ④ **GEL:** Gel Lead-acid Battery.
- ⑤ **No battery:** No battery connected.

⑥ **LFP/14/ 15/LFP 16:** Li-FePO<sub>4</sub> /14/15/16, corresponding to 14-series, 15-series, and 16-series Li-FePO<sub>4</sub> batteries.

⑦ **N13/ N14:** NCM Lithium Battery N13/N14, corresponding to 13-series and 14-series NCM lithium batteries.

- **BMS comm. protocol:** When the BMS port selection item is set to RS485 or CAN, the corresponding lithium battery manufacturer brand shall be selected for communication:

- ① **485 protocol:**

PACE=PACEEX	RUDA=RADAR	AOGUAN=AUTOONE	OULITE=OLITER	CEF=CFGE
XINWANGDA	XiongTao	DAQIN=Dyness	WOW=SRNE	PYL=Pylontech
MIT=FOX ESS	XIX=Xinyi energy	POL=PowMr	GUOX=GOTION	SMK=SMK POWER
VOL=VILION	WES	SGP	GSL	PYT=Pylon tech 2

- ② **CAN protocol:**

UZE=UZENERGY	PYL=Pylontech	Victro	DEY	HONGHE
WOW=SRNE	SGP=SGP	GSL=GSL energy	PYL=Pylontech	RUIXU
RENAC	DUNEXT	General	LUX/LuxPower	

**Note:** Please refer to the actual display on the screen.

- **Battery chg. curr. limit mode(valid for BMS communication):**

- ① **HMI setting:** The maximum battery charging current is limited by the charging current setting value of the inverter.
- ② **BMS setting:** The maximum battery charging current is restricted by the current limit value of the BMS.
- ③ **Inverter setting:** The maximum battery charging current is limited by the derating logic of the device.

- **Batt. Chg Temp Compensation:** Used to select whether to enable temperature compensation.

## 5.2.3.2 Battery Charging

Battery Type	Battery Charging	Battery Discharge
Grid charging enable	<input checked="" type="checkbox"/>	Max. chg. curr. by Grid 2.2A
Generator charging enable	<input checked="" type="checkbox"/>	Max. chg. curr. by gen. 333.0A
Max. chg. voltage	9.5V	Max. chg. current 1.1A
Batt. Recharging voltage	15.0V	Batt. curr. stop chg. 5.5A
Batt. SOC stop chg.	88%	

- **Grid charging enable:** Select whether to allow the grid to charge the battery (not applicable to scheduled charging).
- **Generator charging enable:** Select whether to allow the generator to charge the battery (not applicable to timed charging).
- **Max. chg. voltage:** Set the maximum charging voltage during constant voltage charging of the battery.

- **Batt. Recharging voltage:** After the battery is fully charged, the inverter stops charging. Charging resumes when the battery voltage drops below this value. (This setting is effective when BMS communication is not established or has failed.)
- **Batt. SOC stop chg.:** When the SOC reaches the specified value, battery stops charging. (Valid when BMS communication is normal).
- **Max. chg. curr. by Grid:** Set the maximum charging current from the grid to the battery. (Note: This value refers to the battery-side current, not the grid-side current, and does not apply to scheduled charging.)
- **Max. chg. curr. by gen.:** Set the maximum charging current from the generator to the battery. (Note: This value refers to the battery-side current, not the generator-side current, and does not apply to scheduled charging.)
- **Max. chg. current:** Set the maximum charging current during the constant current phase of battery charging.
- **Batt. curr. stop chg.:** During the constant voltage charging phase, charging will cease when the charging current falls below this value. (Effective when BMS communication is not performed or BMS communication fails).

**Note:** After the battery is fully charged, the inverter stops charging. Charging will resume when the battery SOC drops below this value. (Fixed at Battery Charging Stop SOC - 5%, non-modifiable, effective when BMS communication is normal)

### 5.2.3.3 Battery Discharging

Battery Type	Battery Charging	Battery Discharge	
Batt. volt. stop dischg. in hybrid	9.0V	Batt. SOC stop dischg. in hybrid	11%
Batt. volt. restart dischg.	10.0V	Batt. SOC restart dischg.	55%
Batt. under volt. alarm	20.0V	Batt. under capacity alarm	33%
Batt. volt. low recovery	12.1V	Batt. SOC low fault	44%
Batt. voltage low fault	22.2V	Batt. volt. low delay	2570S
Batt. max. curr. dischg.	5.5A		

- **Batt. under volt. alarm:** When the battery voltage is lower than this value, the inverter will report an under-voltage alarm (notifying the user that the battery is about to stop discharging), but the battery will not stop discharging. (Effective when BMS communication is not established or fails.)

- **Batt. under capacity alarm:** SOC value up to this setting will alarm. The inverter output will not shut down and the fault disappears if the SOC value exceeds 5% of the set value. (Valid when BMS communication is normal)
- **Batt. volt low recovery:** When the battery report voltage low fault, the battery voltage reach this setting, the fault will be cleared.
- **Batt. SOC low fault:** When the battery SOC is lower than this value, the inverter will report a low battery SOC fault and stop discharging. (Effective when BMS communication is normal.)
- **Batt. voltage low fault:** When the battery voltage is lower than this value and after the "Discharge Stop Delay Time" elapses, the inverter will report a low battery voltage fault and stop discharging.
- **Batt. volt. low delay:** Battery stop discharge delay time.
- **Batt. max. curr. dischg.:** Set the max. battery discharger current.

**The following settings are only effective in hybrid grid operation mode:**

- **Batt. volt. stop dischg. in hybrid:** Discharging stops when the battery voltage is lower than this value. (Effective when BMS communication is not established or fails.)
- **Batt. SOC stop dischg. in hybrid:** Discharging stops when the battery SOC is lower than this value. (Effective when BMS communication is normal.)
- **Batt. volt. restart dischg. :** The inverter stops discharging after low battery voltage, and resumes discharging when the battery voltage rises above this value. (Effective when BMS communication is not established or fails.)
- **Batt. SOC restart dischg.:** The inverter stops discharging after low battery capacity, and resumes discharging when the battery SOC rises above this value. (Effective when BMS communication is normal.)

## 5.2.4 Grid Connection Setup

### 5.2.4.1 Basic Page

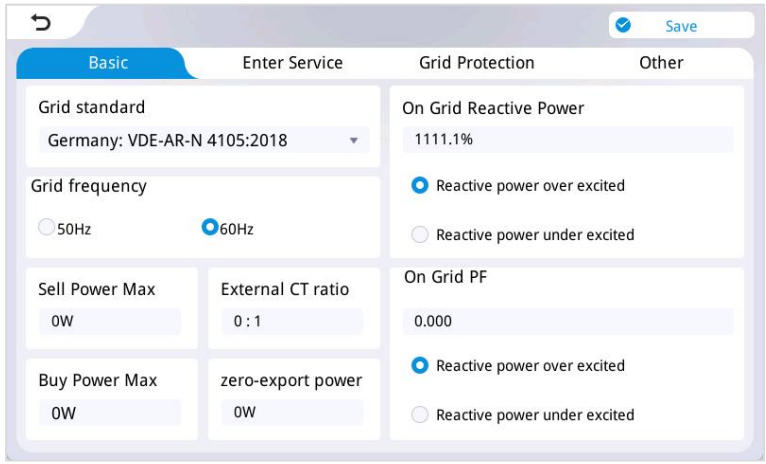

- **Grid frequency:** Select the local grid frequency (50Hz/60Hz).
- **Sell Power Max:** Set the maximum power for feeding into the grid.
- **Buy Power Max:** Maximum power drawn from the grid. If the grid charging power + load power by the grid exceeds this setting, the inverter will prioritize reducing the grid charging power to avoid exceeding the buying power threshold.

- **External CT ratio:** When connecting an external CT, enter the ratio on the CT specification. (CT is fixed for grid-side power collection.)
- **zero-export power:** Error calibration power for anti-backflow, recommended to be set between 20-100W. Due to sampling accuracy issues, in order to bring the anti-backflow side power close to 0W:
  - ① When buying power  $P > 0$ , set this value to  $P$ ;
  - ② When selling power  $P > 0$ , set this value to  $-P$ .
- **On Grid Reactive Power:** Setting range 0-100%, expressed as a percentage of reactive power.
- **Reactive power over/under excited:** "over" indicates 0%-100% / "under" indicates -100% ~ 0%.
- **On Grid PF:** Setting range 0.8 ~ 1.
- **Reactive power over / under excited:** "over" indicates 0.8 ~ 1 / "under" indicates -0.8 ~ -1
- **Grid standard (subject to the actual display on the screen.):**

Austria: TE-OVE	Thailand: PEA-MEA PEA-MEA	Italy: CEI 0-21:2022/V1:2022
Germany: VDE-AR-N 4105:2018	Europe: EN 50549-1	Spain: UNE 217002: 2020-10
United States: IEEE Std 1547 2018/IEEE1547		Great Britain: G99
South Africa: NRS097	Australia: AS4777.2 Australia A	Myanmar
Poland: EN 50549-1	Australia: AS4777.2 New Zealand	Thailand: PEA-MEA
Ireland: EN50549-IE	United States: UL1741	Northern Ireland: G99/NI
Great Britain: G98	Puerto Rico	Uninitialized

### 5.2.4.2 Enter Service (User modification not recommended)

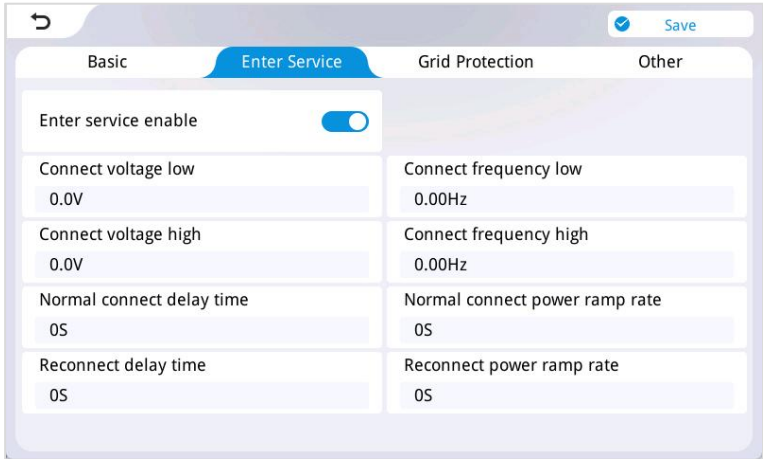

Enter service enable	<input checked="" type="checkbox"/>
Connect voltage low	0.0V
Connect voltage high	0.0V
Normal connect delay time	0S
Reconnect delay time	0S
Connect frequency low	0.00Hz
Connect frequency high	0.00Hz
Normal connect power ramp rate	0S
Reconnect power ramp rate	0S

- **Enter service enable:** Grid connection startup setting (enabled by default).
- **Connect voltage low:** Minimum voltage requirement for grid connection.
- **Connect frequency low:** Minimum frequency requirement for grid connection.
- **Connect voltage high:** Maximum voltage requirement for grid connection.
- **Connect frequency high:** Maximum frequency requirement for grid connection.

- **Normal connect delay time:** The delay time for the inverter to connect to the grid when the grid first meets the connection requirements.
- **Normal connect power ramp rate:** The ramp rate of grid-connected power for the first grid connection.
- **Reconnect delay time:** Grid disconnection and reconnection, grid connection delay time.
- **Reconnect power ramp Rate:** Grid disconnection reconnection, rate of rise of grid-connected power.

### 5.2.4.3 Grid Protection (User modification not recommended)

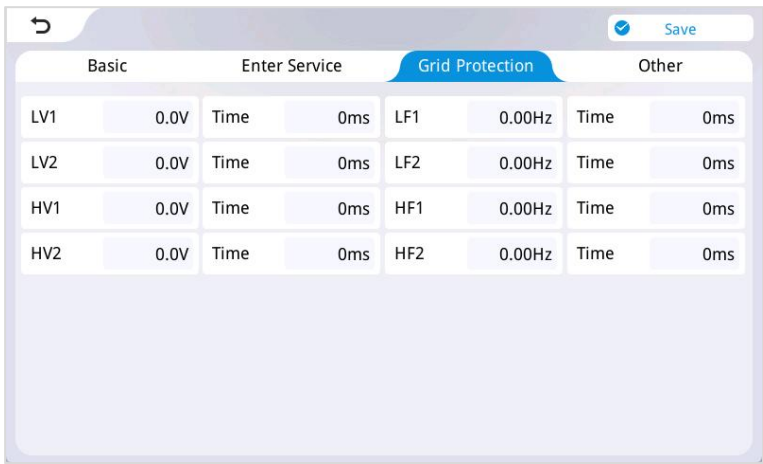

LV1	0.0V	Time	0ms	LF1	0.00Hz	Time	0ms
LV2	0.0V	Time	0ms	LF2	0.00Hz	Time	0ms
HV1	0.0V	Time	0ms	HF1	0.00Hz	Time	0ms
HV2	0.0V	Time	0ms	HF2	0.00Hz	Time	0ms

- **Time:** Time Protection Response Time.
- **LV1:**  
Class 1 undervoltage protection point. When the grid voltage drops below this threshold and remains so for the corresponding protection response time, the inverter shall disconnect from the grid.

- **LF1:**  
Class 1 underfrequency protection point. When the grid frequency drops below this threshold and remains below it for the corresponding protection response time, the inverter shall disconnect from the grid.
- **LV2:**  
Class 2 undervoltage protection point. When the grid voltage drops below this threshold and remains below it for the corresponding protection response time, the inverter shall initiate grid disconnection.
- **LF2:**  
Class 2 underfrequency protection point. When the grid frequency drops below this threshold and remains below it for the corresponding protection response time, the inverter shall disconnect from the grid.

- **HV1:**  
Class 1 overvoltage protection point.  
When the grid voltage rises above this threshold and remains above it for the corresponding protection response time, the inverter shall disconnect from the grid.
- **HF1:**  
Class 1 overfrequency protection point.  
When the grid frequency exceeds this threshold and remains above it for the corresponding protection response time, the inverter shall disconnect from the grid.
- **HV2:**  
Class 2 overvoltage protection point.  
When the grid voltage exceeds this threshold and persists above it for the preconfigured protection response time, the inverter shall initiate grid disconnection.
- **HF2:**  
Class 2 overfrequency protection point.  
When the grid frequency exceeds this threshold and remains above it for the specified protection response time, the inverter shall disconnect from the grid.

#### 5.2.4.4 Other Page (User modification not recommended)

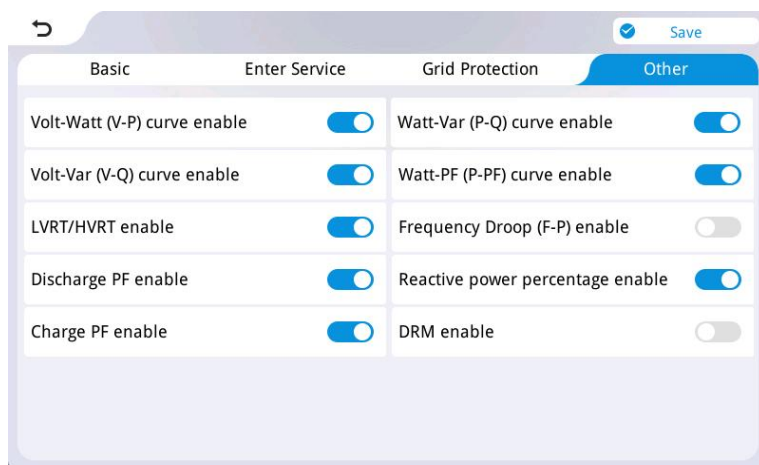

- **Volt-Watt (V-P) curve enable:**  
Regulates the active power of the inverter according to the set grid voltage.
- **Volt-Var (V-Q) curve enable:**  
Adjustment of the inverter reactive power according to the set grid voltage.
- **LVRT/HVRT enable:**  
Adjustment of the grid HV ride-through / LV ride-through values.

- **LFRT/HFRT enable:** According to the preset grid high-frequency/low-frequency ride-through thresholds.
- **Watt-Var (P-Q) curve enable:** Adjustment of the inverter reactive power according to the set active power.
- **Watt-PF (P-PF) curve enable:** Adjustment of the inverter power factor according to the set active power.
- **Frequency Droop (F-P) enable:** Adjustment of inverter output power according to grid frequency.
- **DRM Enable:** Australia only.

## 5.2.5 Advanced Setup

### 5.2.5.1 Generator

#### ● Generator work mode:

① **Generator input:** When the generator is connected to the "Gen port", select the "Generator input".

② **Micro inverter input:** When the grid-tied inverter is connected to the "Gen Port" of the hybrid inverter, select the "Microinverter Input".

③ **Smart load:** When the load is connected to the "Gen port", select "Smart load output".

● **Grid always to smart load enable:** When the inverter operates in hybrid grid mode, the smart load remains constantly enabled.

● **Generator rate power:** Setting the rated power of the generator.

● **Off-grid disconnect smart load:** When the inverter operates in off-grid mode, the smart load shall be immediately disabled.

● **Turn on the smart load SOC:** When battery SOC > this value, enable smart load. (Effective when BMS communication is normal)

● **Turn off the smart load SOC:** When battery SOC < this value, disable smart load. (Effective when BMS communication is normal).

● **Turn on the smart load voltage:** When battery voltage > this value, enable smart load. (Effective when BMS communication is not established or fails)

● **Turn off the smart load voltage:** When battery voltage < this value, disable smart load. (Effective when BMS communication is not established or fails).

● **Dry contact function setting:** ① Generator control. ② PV on grid energy monitoring. ③ Grid voltage monitoring.

● **Grid voltage monitoring threshold:** When the grid voltage exceeds the threshold, the dry contact operates.

● **PV on grid energy monitoring threshold:** When the PV grid-connected energy exceeds the threshold, the dry contact operates.



## 5.2.5.2 Wind Turbine



MPPT	V1	C1	V2	C2	V3	C3	V4	C4
MPPT 1	11V	22A	3V	4A	5V	6A	7V	8A
MPPT 2	5V	6A	6V	66A	7V	77A	8V	88A
MPPT 3	9V	99A	10V	100A	11V	110A	12V	120A
MPPT 4	13V	130A	14V	140A				

- **MPPT1/2/3:** Enable for wind turbine input.
- **V1/2/3/4.../14:** Voltage parameters for the wind turbine.
- **C1/2/3/4.../14:** Current parameters for the wind turbine.

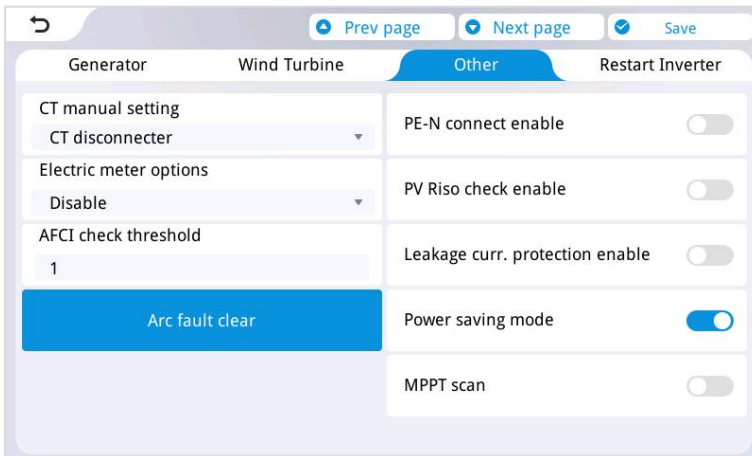
## 5.2.5.3 Other Page

- **CT manual setting:** Select the CT direction based on the CT installation (ensure that the direction of each phase CT is consistent).
  - ① When the arrow on the CT points to the inverter, set it to "Point to Inverter".
  - ② When the arrow on the CT points to the grid, set it to "Point to Grid".
- **Electric meter options:** Whether to enable meter.
- **PE-N Connect enable:** Enable automatic switching of PE-N connections.
- **PV Riso check enable:** Enable PV insulation impedance detection.
- **Leakage curr. protection enable:** Enable leakage current protection.
- **Power saving mode:** When the energy-saving mode is activated:
  - ① If the load power is less than 35W, the inverter output will turn off after 5 min;
  - ② If the load power is greater than 56W, the inverter output will restart immediately.

- **MPPT scan:** When this function is enabled: The inverter will perform an MPPT global scan every 30 min. During the scan, the photovoltaic power will drop to 0W and then reach the maximum power point.

**Note:** Applicable to scenarios where the photovoltaic panels cannot output maximum power due to shading or other reasons.

- **Smart Meter 1 Address**
- **AFCI check threshold:** AFCI sensitivity setting range: 0-100.  
0: AFCI disabled; 1-100: AFCI enabled, with higher values indicating lower sensitivity.
- **Arc fault clear**

- **Smart meter connect point:** Select the corresponding object based on the power to be collected by the meter.
  - ① When the meter is required to collect micro-inverter power, select "Micro inverter" (valid only when the micro-inverter is connected to the grid side);
  - ② When the meter is required to collect grid power, select "Grid".

## 5.2.5.4 Restart Inverter

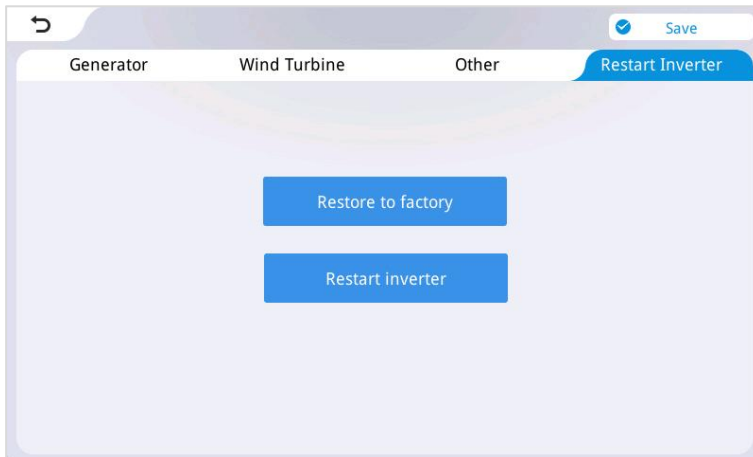

- **Restore to factory:** Reset all inverter settings.
- **Restart inverter:** Restart the inverter.

## 5.2.6 LCD Display WiFi Setting

### 5.2.6.1 Search and Select Network

Click the [Refresh] button, select the target network name from the hotspot list, and click to enter the password input interface.

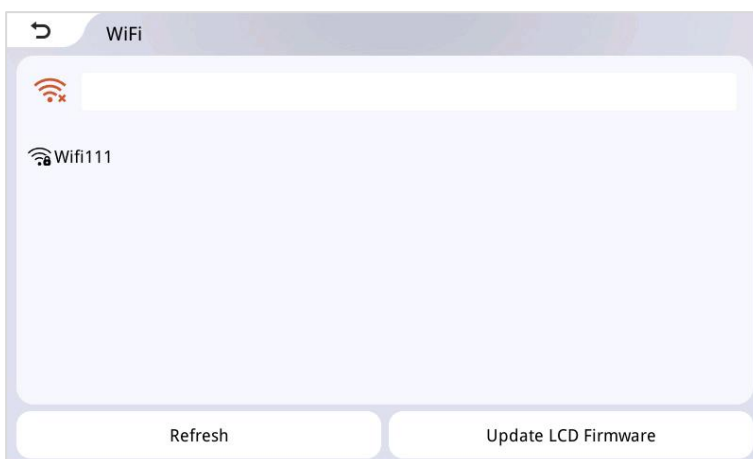

- **Refresh:** Refresh the WiFi network to obtain WiFi hotspots.
- **Update LCD Firmware:** Update the LCD display firmware.

### 5.2.6.2 Enter and Verify Password

Enter the WiFi network password (supporting numbers and letters) in the password input field; click [Connect] to confirm and establish the connection.

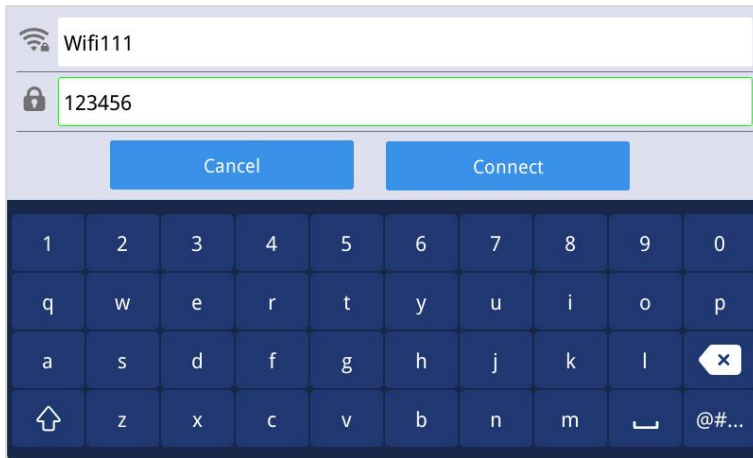

- **Cancel:** Exit the password data interface.
- **Connect:** Connect to the WiFi network.

### 5.2.7 Firmware Upgrade via USB Drive

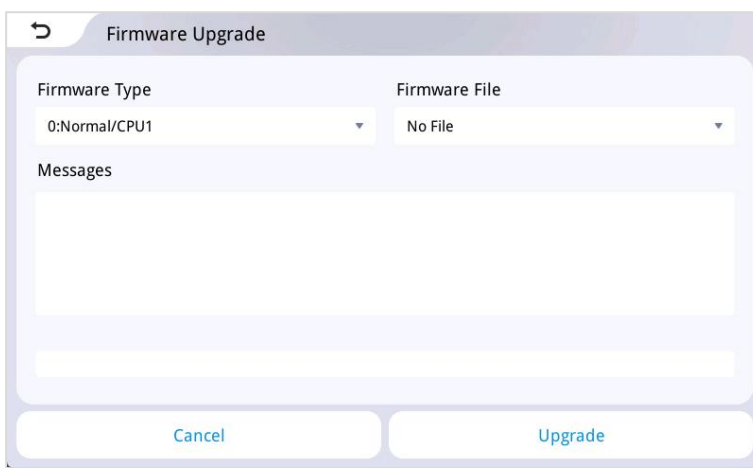

- **Firmware Type:**
  - ① Firmware type.
  - ② **0 : Normal/CPU1** — for upgrading the inverter is primary CPU1 program.
  - ③ **1 : CPU2** — for upgrading the inverter is primary CPU2 program.
  - ④ **2 : AUX DSP** — for upgrading the inverter is auxiliary DSP program.
  - ⑤ **3 : AFCI MCU** — for upgrading the AFCI chip program.
  - ⑥ **4 : BMS MCU** — for upgrading the battery BMS program.

- **Firmware File:** Firmware file in the USB drive.
- **Cancel:** Cancel the upgrade.
- **Upgrade:** Update the firmware.

## 5.3 Time-slot Charging/Discharging Function

The product have the function of charging and discharging by different time periods. Users can set different charging and discharging time periods according to the local peak and valley electricity prices, so as to make rational use of the utility power and photovoltaic energy. When the utility power price is expensive, the battery inverter can be used to supply electricity to the load. When the utility power price is low, the utility

power can be used to supply power to the load and charge the battery, which can help users save electricity bills to the greatest extent.

Users can enable or disable the time-slot charging and the time-slot discharging functions in the settings menu, and configure the charging and discharging periods, including the scheduled grid-charging start time and duration, as well as the scheduled battery-discharging start time and duration.



The following is an example to assist users in understanding this feature.

Before using this function for the first time, please set the local time in the parameters menu; afterwards, Users can set corresponding time periods according to the electricity prices during peak and off-peak hours in the local area.

The device also supports configuring battery discharge outside the scheduled discharge periods.

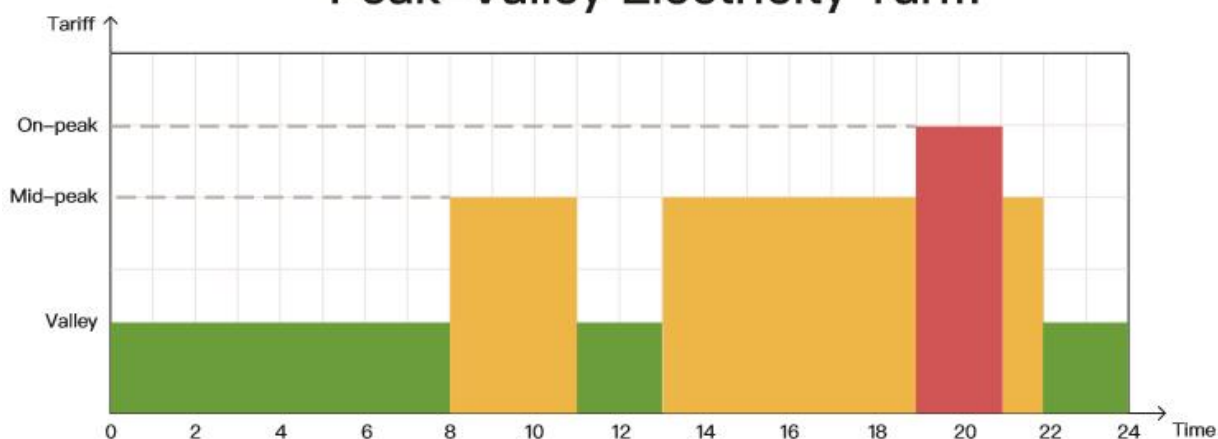
## Peak-Valley Electricity Tariff



Time-slot Utility Charging & Loading Function	Time-slot Battery Discharging Function
	
<p>With 3 definable periods, the user can freely set the mains charging/supplying power time within the range of 00:00 to 23:59. During the time period set by the user, if PV energy is available, PV energy will be used first, and if PV energy is not available or insufficient, utility energy will be used as a supplement.</p>	<p>With 3 definable time periods, users can freely set the battery discharge time within the range of 00:00 to 23:59. During the time set by the user, the inverter will give priority to the battery inverter to carry the load, and if the battery power is insufficient, the inverter will automatically switch to mains power to ensure stable operation of the load.</p>

## 5.4 Battery Parameters

### 5.4.1 Lead-acid Battery

Battery type Parameters	Sealed lead acid battery (SLD)	Gel lead acid battery (GEL)	Flooded lead acid battery (FLD)	User-defined (USE)	Adjustable
Overvoltage Disconnect Voltage	60V	60V	60V	60V	
Battery fully charged recovery point	52V	52V	52V	52V	√
Boost Charging Voltage	57.6	57.6	57.6	40 ~ 60V	√
Undervoltage Alarm Voltage	44V	44V	44V	40 ~ 60V	√
Undervoltage Alarm Recovery Voltage	Undervoltage alarm voltage+0.8V				
Low Voltage Disconnect Voltage	42V	42V	42V	40 ~ 60V	√
Low Voltage Disconnect Recovery Voltage	52V	52V	52V	52V	√
Discharge Limit Voltage	57.6	57.6	57.6	40 ~ 60V	√
Over-discharge Delay Time	5s	5s	5s	1 ~ 30s	√
Boost Charge Duration	120 min	120 min	120 min	10 ~ 900 min	√

### 5.4.2 Lithium-ion Battery

Battery type Parameters	Ternary (N13)	Ternary (N14)	LFP (L16)	LFP (L15)	LFP (L14)	Adjustable
Overvoltage Disconnect Voltage	60V	60V	60V	60V	60V	
Battery Fully Charged Recovery Point	50.4V	54.8V	53.6V	50.4V	47.6V	√
Equalization Charging Voltage	-	-	-	-	-	√
Boost Charging Voltage	53.2V	57.6V	56.8V	53.2V	49.2V	√
Undervoltage Alarm Voltage (Fault 01)	43.6V	46.8V	49.6V	46.4V	43.2V	√
Undervoltage Alarm Recovery Voltage (Fault 01)	Undervoltage alarm voltage+0.8V					
Low Voltage Disconnect Voltage (Fault 04)	38.8V	42V	48.8V	45.6V	42V	√
Low Voltage Disconnect Recovery Voltage (Fault 04)	46V	49.6V	52.8V	49.6V	46V	√
Discharge Limit Voltage	36.4V	39.2V	46.4V	43.6V	40.8V	√
Over-discharge Delay Time	30s	30s	30s	30s	30s	√
Boost Charge Duration	120 min	120 min	120 min	120 min	120 min	√

# 6. Communication

## 6.1 Product Overview

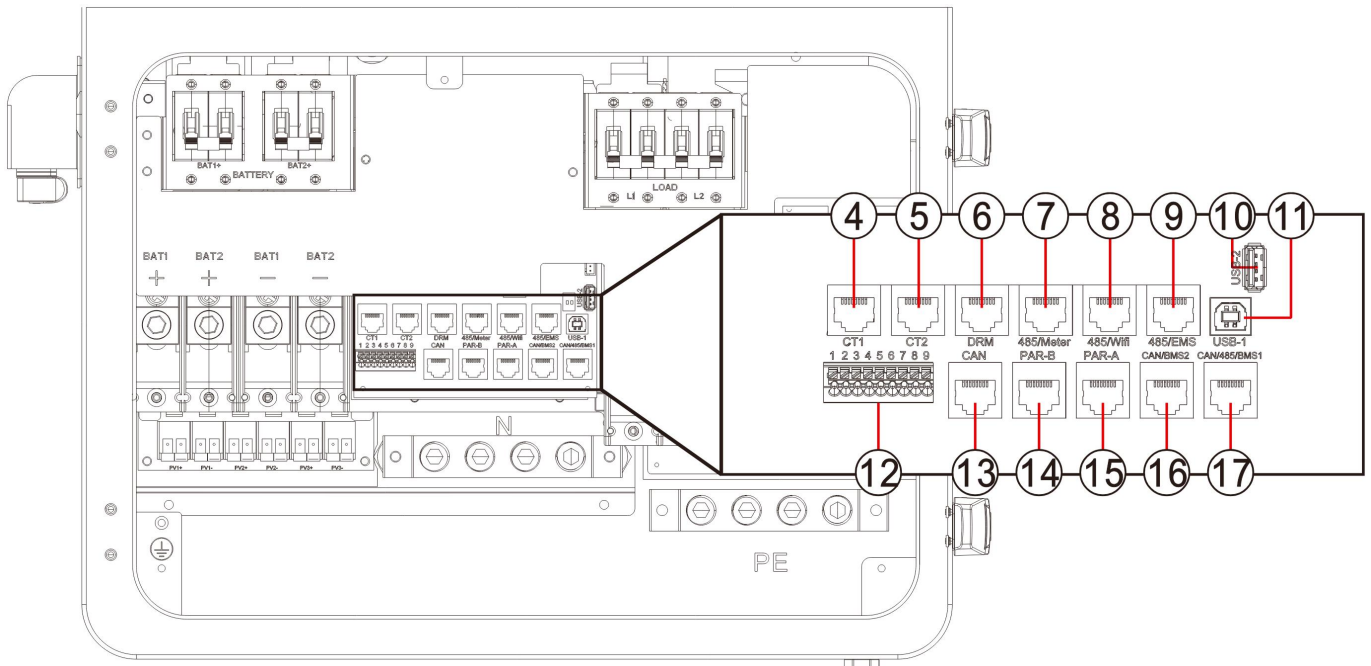

4	Grid CT1	5	Micro-inverter CT2	6	DRM Port
7	485/Meter Port	8	485/WiFi Port	9	485/EMS Port
10	Display USB-2 Port	11	USB-1 Port	12	Dry Contact Interface SC1
13	CAN2 Communication Port	14	Parallel Port-B	15	Parallel Port-A
16	CAN/BMS2 Port	17	CAN/485/BMS1 Port	18	Generator Input (L1+L2)

## 6.2 USB-1 Port

The user can read and modify device parameters through this port by using the host software. Please contact us for the host software installation package if you require one.

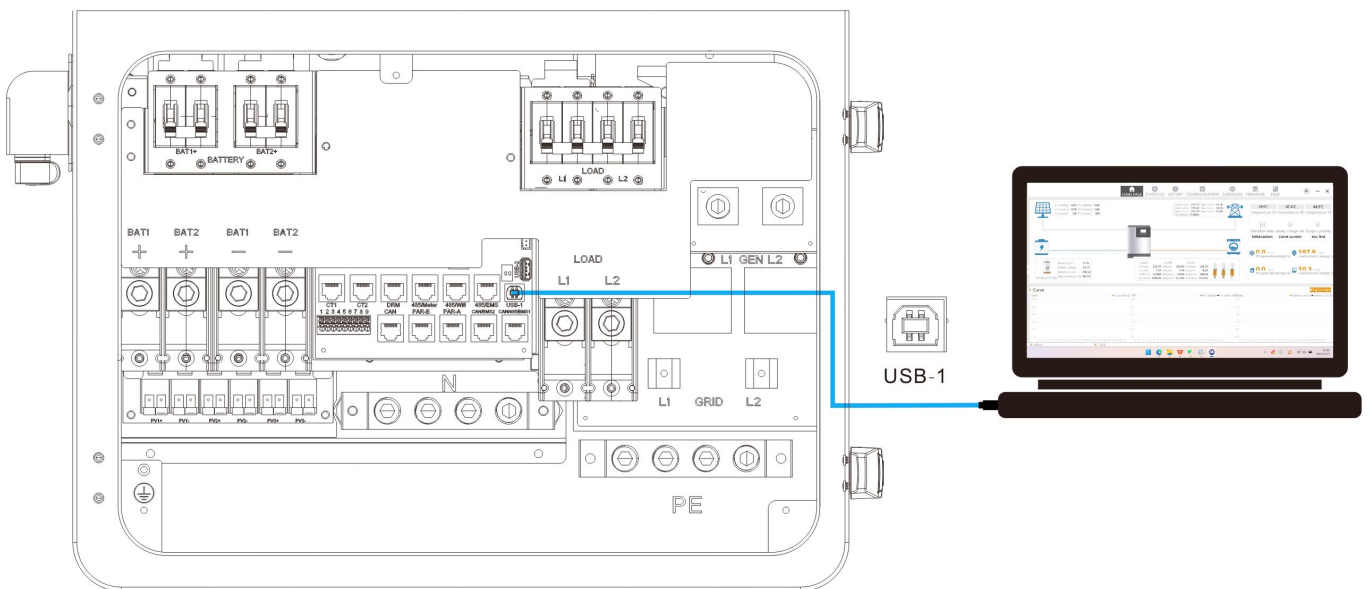

## 6.3 USB-2 Display Port

It is used to update the screen firmware.

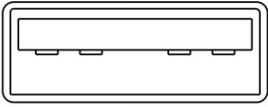

## 6.4 WiFi Communication Function

The WiFi communication port can be connected to the optional RS485-to-WiFi/GPRS communication module independently developed by our company. With this module installed, users can connect to our inverters and monitor the operating status and parameters of the inverters via the mobile APP.

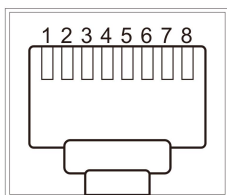
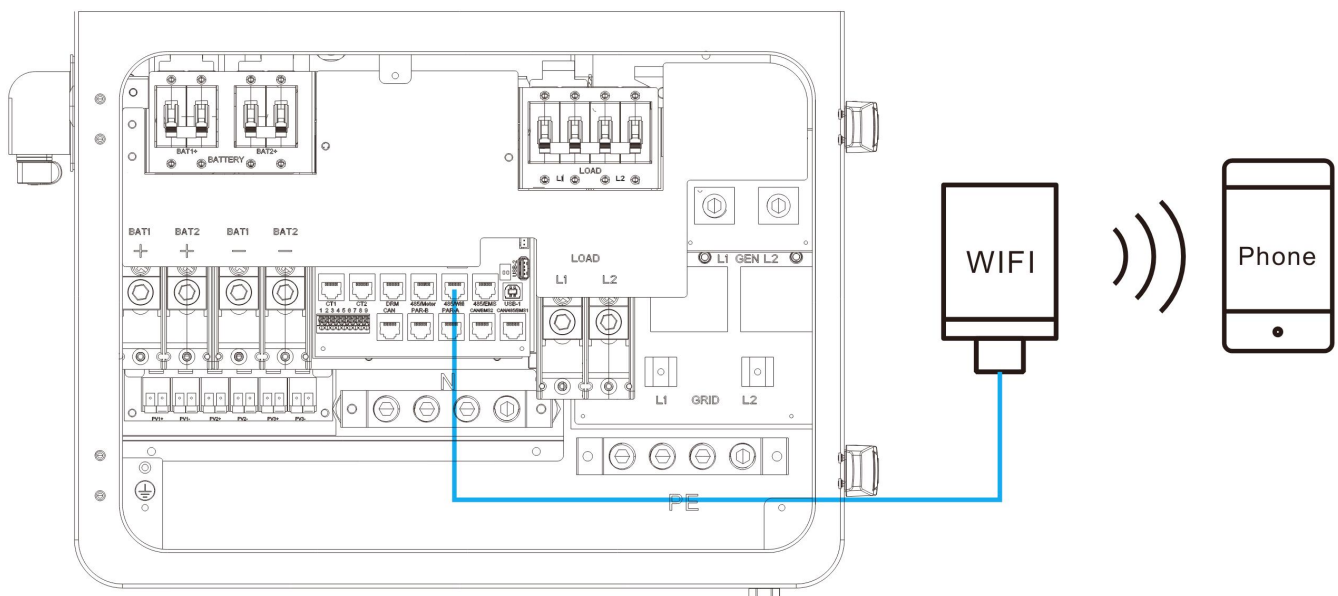

485/WIFI

RJ45	Pin 1	Pin 2	Pin 3	Pin 4	Pin 5	Pin 6	Pin 7	Pin 8
Definition	5V	GND	/	/	/	/	RS485-A	RS485-B

## 6.5 CAN/RS485/BMS1 Port

The CAN/RS485/BMS1 interface is used to connect to the BMS lithium battery.

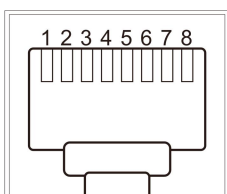

CAN/485/BMS1

RJ45	Pin 1	Pin 2	Pin 3	Pin 4	Pin 5	Pin 6	Pin 7	Pin 8
Definition	RS485-B	RS485-A	/	CANH	CANL	/	RS485-A	RS485-B

### NOTICE

If you need to use the inverter to communicate with the lithium battery BMS, please contact us for the communication protocol or upgrade the inverter to the appropriate software programme.

## 6.6 CAN Port

The CAN port is used to connect to the BMS of lithium battery.

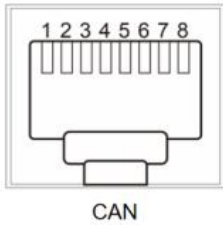

RJ45	Pin 1	Pin 2	Pin 3	Pin 4	Pin 5	Pin 6	Pin 7	Pin 8
Definition	/	/	/	CANH	CANL	/	/	/

## 6.7 DRM(Only Australia)

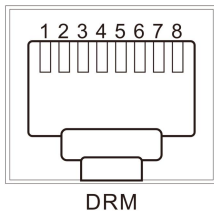

RJ45	Pin 1	Pin 2	Pin 3	Pin 4	Pin 5	Pin 6	Pin 7	Pin 8
Definition	DRM5	DRM6	DRM7	DRM8	RefGen	COM/ DRM0	V+	V-

MODEL	RJ45 socket asserted by shorting pins		Requirement
DRM0	5	6	Operate the disconnection device.
DRM5	1	5	Do not generate power to grid.
DRM6	2	5	Do not generate at more than 50% of rated power.
DRM7	3	5	Do not generate at more than 75% of rated power AND Sink reactive power if capable.
DRM8	4	5	Increase power generation (subject to constraints from other active DRM) .

## 6.8 External CT Prot

**⚠ Important Note:** CT1 is used for grid-side current monitoring and must be reliably connected to the main grid circuit to ensure matching with system electrical parameters; CT2 should be accurately connected to the AC output terminal of the micro-inverter for real-time monitoring of the inverter's current output status.

- 1.Split Core Current Transformer (CT) dimension: (mm)
- 2.Secondary output cable length is 4m (157.48 in).

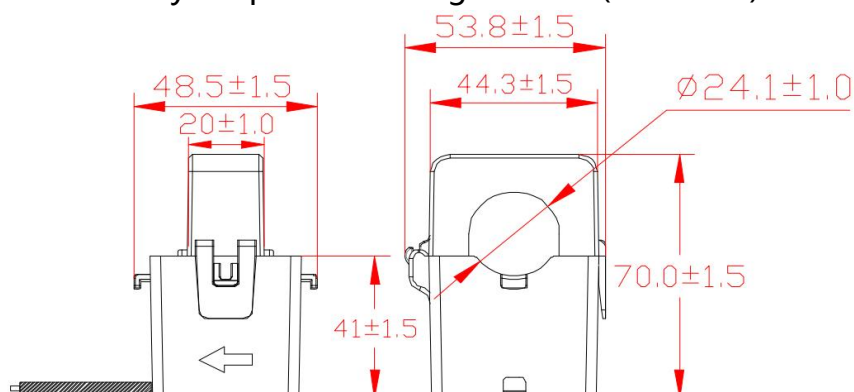

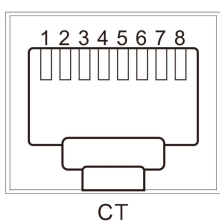
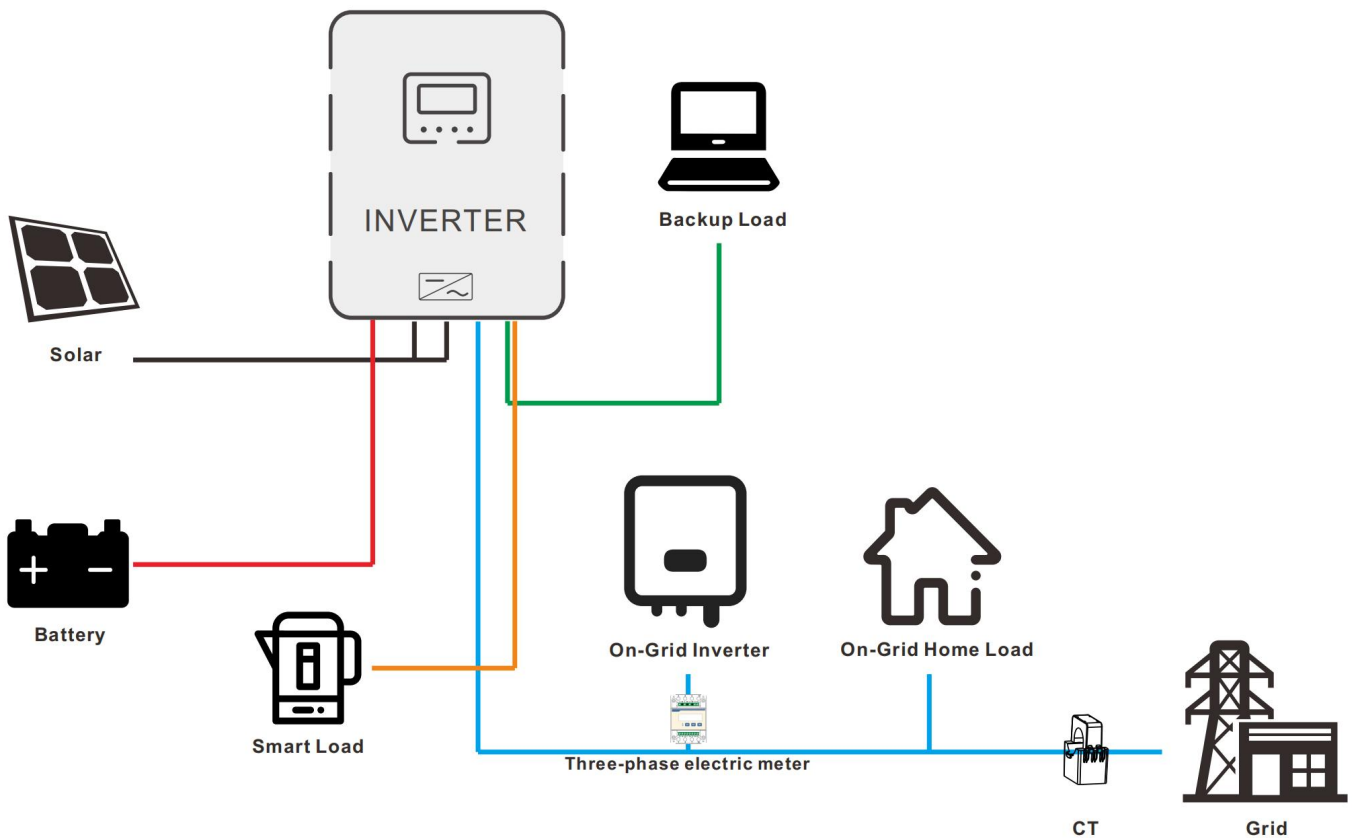
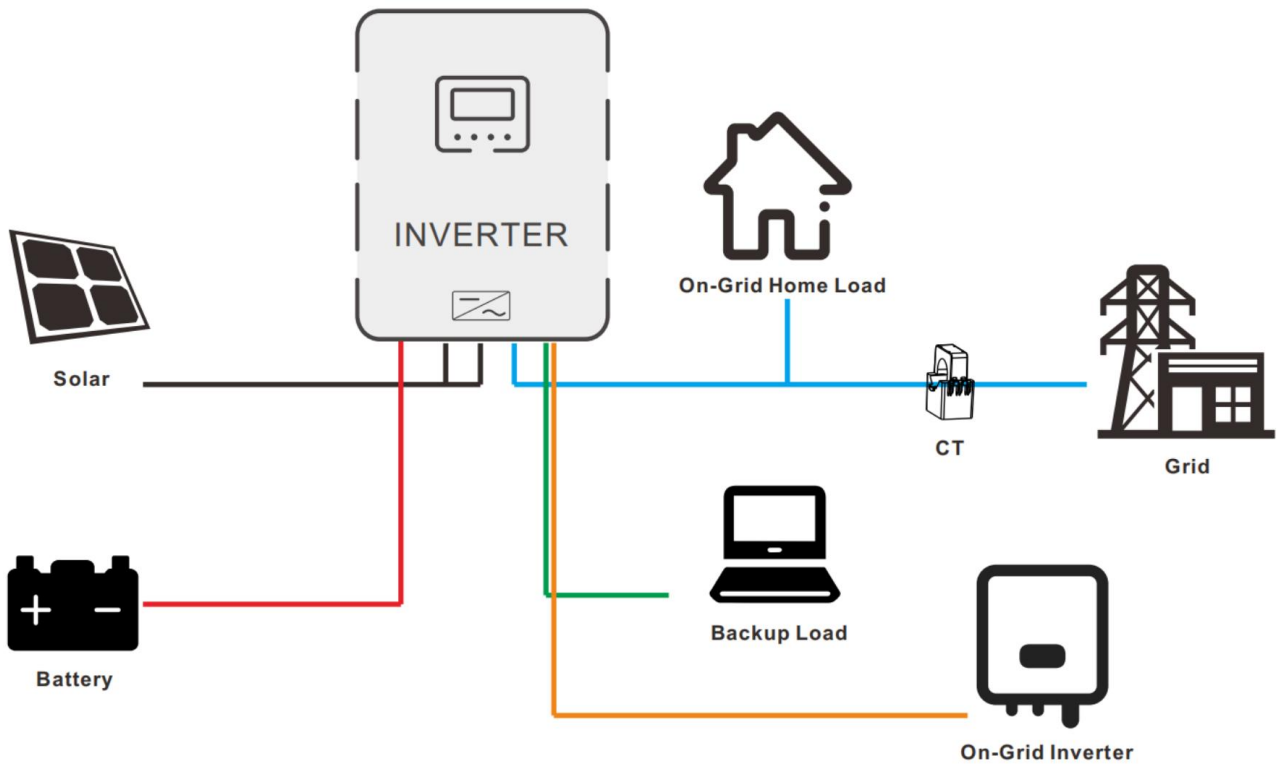

RJ45	Pin 1	Pin 2	Pin 3	Pin 4	Pin 5	Pin 6	Pin 7	Pin 8
Definition	CT3+	CT3-	/	CT2+	CT2-	/	CT1+	CT1-

## 6.9 DIP Switch Configuration



This DIP switch is a resistor matching switch for parallel communication. When performing parallel CAN communication, the first and last units in the parallel system must have DIP switches 1 and 2 set to the up position(ON).

## 6.10 Dry Contact Function

The dry contact port has 5 functions:

- ① Generator remote start/stop;
- ② Temperature sampling (reserved);
- ③ RSD power supply;
- ④ Remote signal transmission;
- ⑤ Remote signal reception.

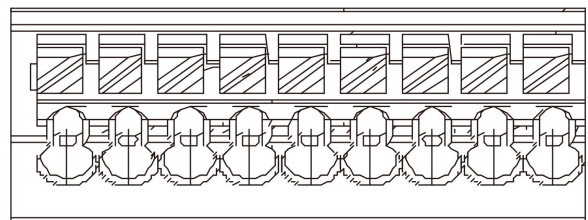

1 2 3 4 5 6 7 8 9

Function	Definition
Remote start/stop of the generator	1-2: NC; 1-3: NO Remote generator shutdown: Pins 1 to 2 are normally closed; pins 1 to 3 are normally opened.
Temperature sampling (reserved)	Pins 9 and 5 can be used for battery temperature sampling compensation.
RSD power supply	Pin 9 is GND, pin 4 is RSD 12V+.
Remote signal transmission	Pins 9 and 7/8: DSP internal signal transmission.
Remote signal reception	Pins 9 and 6: DSP internal signal reception.

### NOTICE

If you need to use the remote start/stop function of the generator with dry contact, ensure that the generator has ATS and supports remote start/stop.

## 6.11 Remote Monitoring

When operating the equipment, it is recommended to enable a remote monitoring configuration.

The inverter supports APP application to provide more comprehensive and intuitive monitoring of power plant data, creating the ultimate user experience with extremely simplified product design thinking to meet the convenient operation of offline applications.

## 6.11.1 Download App

- **App Download:** Android system can search "SOLARMAN Smart " through application market/store for downloading, while IOS system can choose to download SOLARMAN Smart APP in Apple Store.
- **QR code download:** SOLARMAN Smart APP can also support scanning QR code with mobile phone for downloading. Please scan the code with mobile phone.



## 6.11.2 Stick Logger Installation

Step1: Install the fixed bracket on the wall next to the inverter.

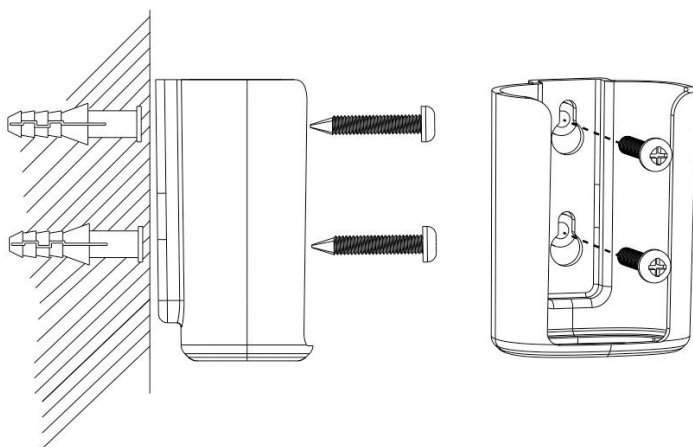

Step2: Connect inverter with data logger, and tighten it.

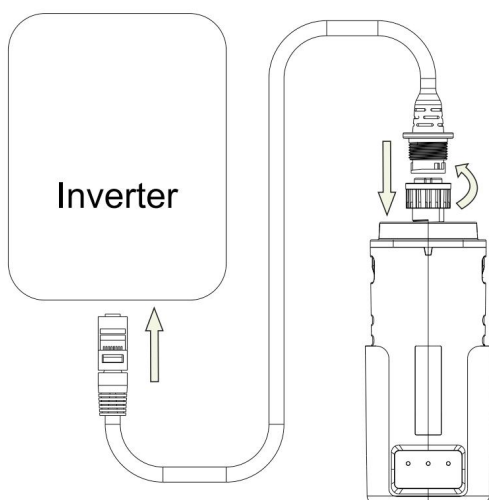

The normal operation status of the stick logger, when router connected to the network normally:

- ① Connection to the server succeeded: NET light keeps on after the logger powered on.
- ② Logger running normally: READY light flashes.
- ③ Connection to the inverter succeeded: COM light keeps on.

## 6.11.3 SOLARMAN Smart APP Operation

Please make sure Bluetooth and WiFi are ON and the router can connect to the network normally.

### ■ Registration

Go to SOLARMAN Smart and register.

Click "Register" and create an account here.

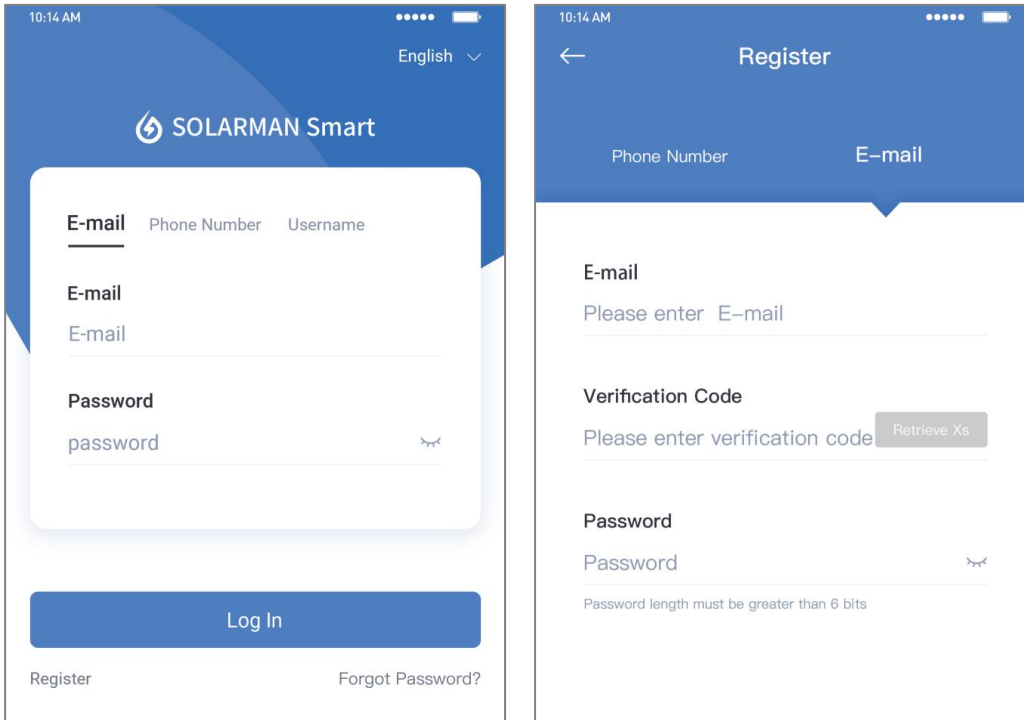

The left screenshot shows the SOLARMAN Smart app interface. At the top, there is a language selector set to "English". Below the app logo, there are three tabs: "E-mail", "Phone Number", and "Username". The "E-mail" tab is selected. There are two input fields: "E-mail" and "Password" (containing the text "password"). A blue "Log In" button is at the bottom. Below the button are links for "Register" and "Forgot Password?".

The right screenshot shows the "Register" screen. It has a back arrow and the title "Register". There are two tabs: "Phone Number" and "E-mail", with "E-mail" selected. The form includes:
 

- "E-mail" field with the placeholder "Please enter E-mail".
- "Verification Code" field with the placeholder "Please enter verification code" and a "Retrieve Xs" button.
- "Password" field with the placeholder "Password" and a note "Password length must be greater than 6 bits".

### ■ Create a Plant

Click "Add Now" to create your plant.

Please fill in plant basic info and other info here.

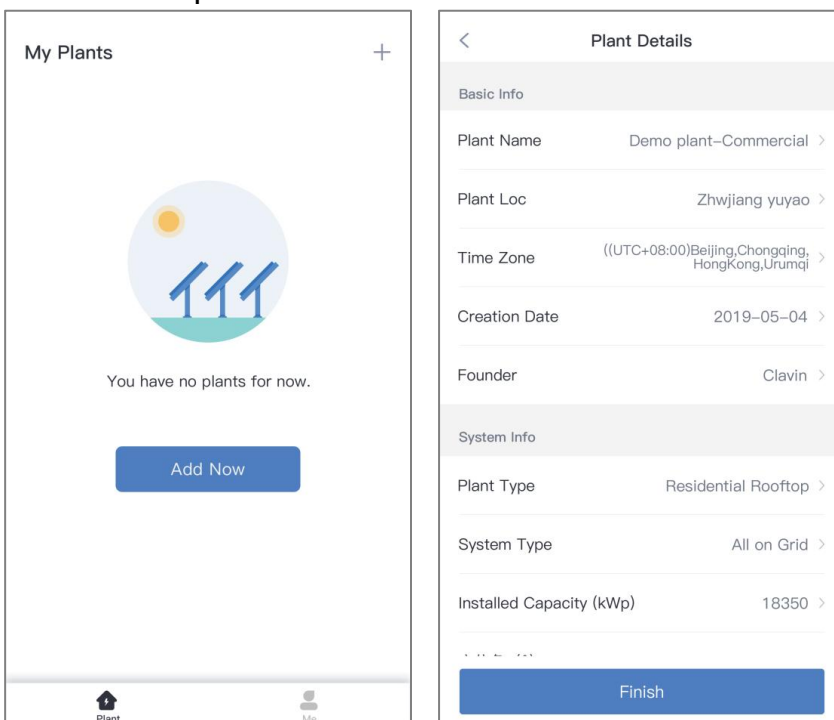

The left screenshot shows the "My Plants" screen. It has a title "My Plants" and a "+" icon. Below is a circular icon representing solar panels. The text says "You have no plants for now." and there is a blue "Add Now" button. At the bottom, there are navigation icons for "Plant" and "Me".

The right screenshot shows the "Plant Details" form. It has a back arrow and the title "Plant Details". The form is divided into two sections:
 

- Basic Info:**
  - Plant Name: Demo plant-Commercial >
  - Plant Loc: Zhwjiang yuyao >
  - Time Zone: ((UTC+08:00)Beijing,Chongqing, HongKong,Urumqi) >
  - Creation Date: 2019-05-04 >
  - Founder: Clavin >
- System Info:**
  - Plant Type: Residential Rooftop >
  - System Type: All on Grid >
  - Installed Capacity (kWp): 18350 >

 At the bottom is a blue "Finish" button.

## ■ Add a Logger

Method 1: Enter logger SN manually.

Method 2: Click the icon in the right and scan to enter logger SN

You can find logger SN in the external packaging or on the logger body

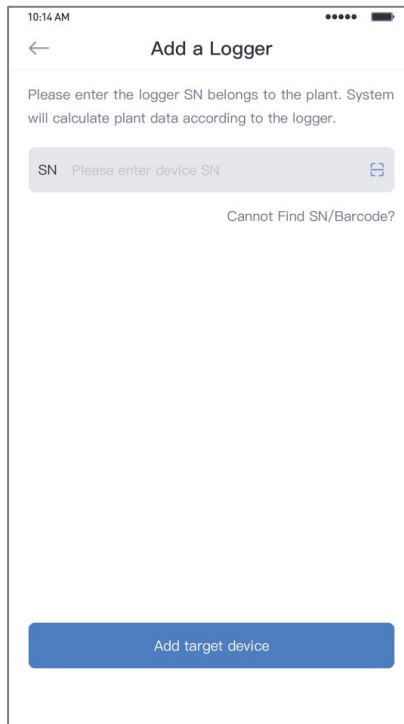
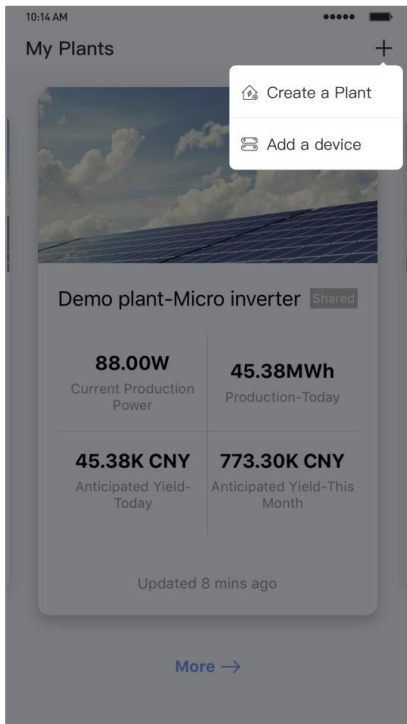

## ■ Network Configuration

Step 1: Click "Go to Configure" to set the network. (Please make sure Bluetooth and WiFi are ON.)

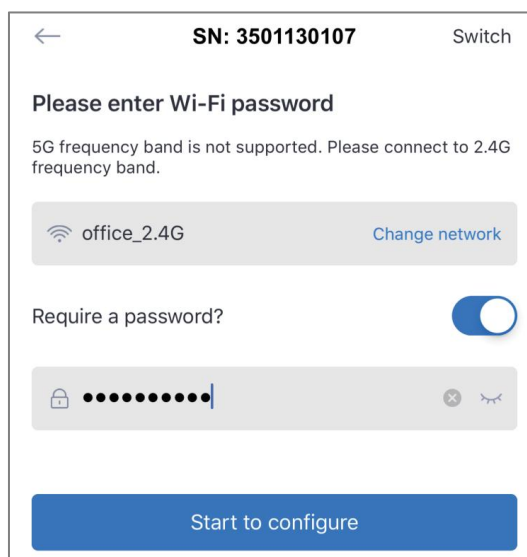
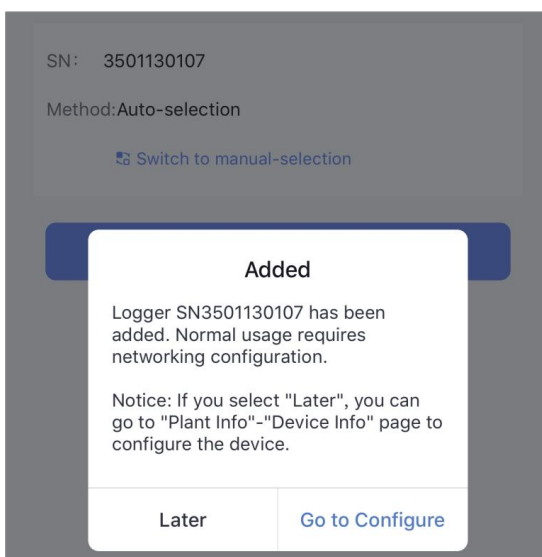

Step 2: Please wait for a few minute. Then click "Done" and view plant data.

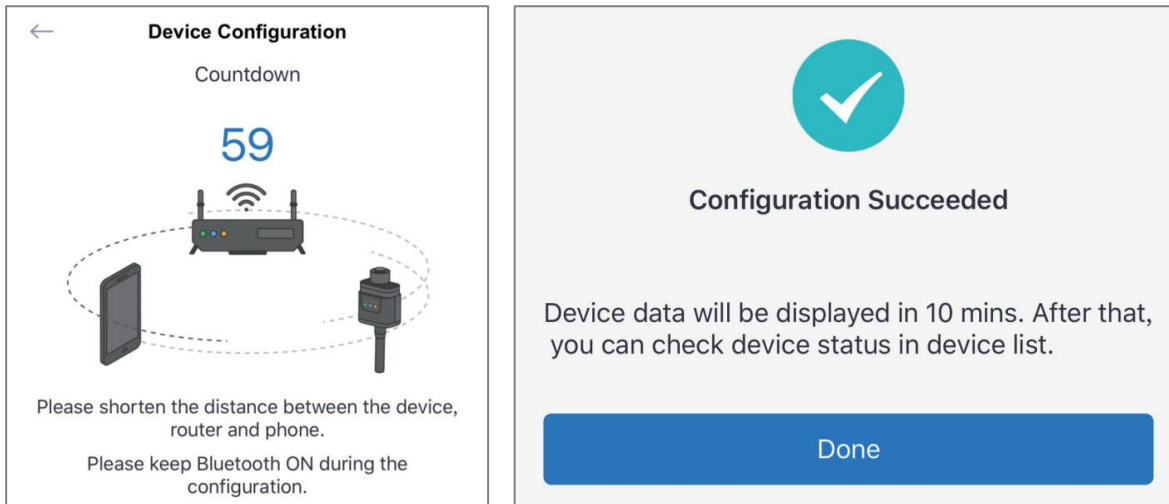

 **NOTICE**

If configuration failure occurs, please check the following reason and try it again.

- Make sure WLAN is ON.
- Make sure WiFi is normal.
- Make sure wireless router does not implement the white-black list.
- Remove the special characters in Wi-Fi network.
- Shorten the distance between the phone and device.
- Try to connect to other Wi-Fi.

## 6.11.4 Plant Detail



After the photovoltaic plant is created and connected to the Logger, you can select the plant to view the corresponding plant data and related settings, including Real time, Statistical, Device, Alerts, Plant Info and Layout, so as to meet the end user's maintenance of plant information and data browsing.

Note: In general, the Plant data can be viewed normally only after 5-10 minutes after the Logger networking configuration is completed.

### ■ Real-time Data

In the "Real time" interface, you can see the real-time data of the Plant, such as real-time generation power and output, energy flow chart, 24-hour power curve, generation and consumption data, etc. The system will display different page layouts according to your plant grid connection type. Please set your plant according to the actual situation.

Depending on your equipment, we recommend:

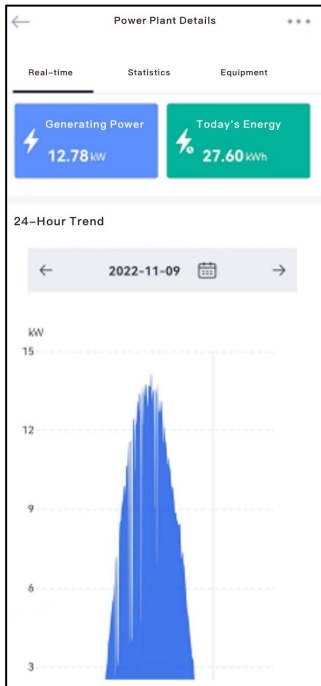

- ① If your equipment (such as inverter) only collects power generation data and transmits it to the grid company, it is recommended that you select "All on Grid" as the System Type of the Plant
- ② If your equipment (such as inverter) collects power generation data and power consumption data at the same time, it is recommended that you select "Self consumption" as the System Type of the Plant
- ③ If your equipment (such as inverter) collects power generation data, power consumption data, battery data and grid data at the same time, it is recommended that you select "Storage System" as the System Type of the Plant.

## ■ Device info

In the "Device" interface, you can view the device information under plant. Select and click a specific device to view the specific information of the device, including the device parameters, data statistics and connection information. Through these data, you can determine whether the device is in normal working state. It can support networking configuration, meter configuration and other functional operations for the corresponding equipment. If the equipment is a logger, networking configuration can be carried out. If the equipment is an electricity meter, meter configuration can be carried out.

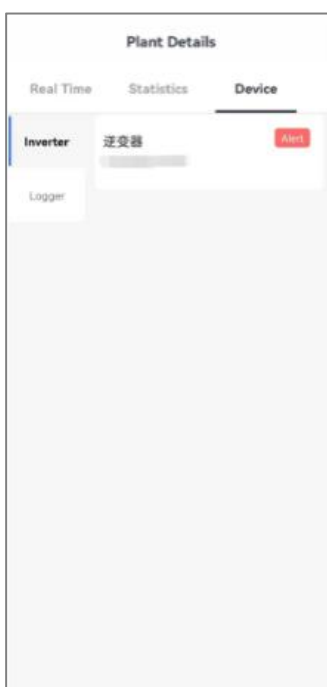

The screenshot shows the '逆变器' (Inverter) device parameters page. It displays 'Electricity Generation' data in a table format.

DC	Voltage	Current	Power
PV1	507.00V	1.90A	963.30W
PV2	514.60V	1.90A	977.74W
PV3	507.00V	1.90A	963.30W
PV4	514.60V	1.90A	977.74W

AC	Voltage	Current	Frequency
R	235.10V	2.70A	50.02Hz
S	233.80V	2.60A	--
T	233.10V	2.60A	--



  

Total DC Input Power:	Total AC Output Power (Active):
3.88kW	3.90kW
Peak Active Power:	Cumulative Production (Active):
14.15kW	13.47MWh
Daily Production (Active):	
84.40kWh	

## 6.11.5 Abnormal State Processing

If the data on platform is abnormal when the stick logger is running, please check the table below and according to the status of indicator lights to complete a simple troubleshooting. If it still can not be resolved or indicator lights status do not show in the table below, please contact Customer Support.

(Note: Please using the following table query after power-on for 2mins at least.)

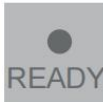
NET  NET	COM  COM	READY  READY	Fault Description	Fault Cause	Solution
Any state	OFF	Slow flash	Communicate with inverter abnormally	1.Connection between stick logger and inverter loosen. 2.Inverter does not match with stick logger's communication rate.	1.Check the connection between stick logger and inverter. Remove the stick logger and install again. 2.Check inverter's communication rate to see if it matches with stick logger's. 3.Long press Reset button for 5s, reboot stick logger.
OFF	ON	Slow flash	Connection between logger and router abnormal	1.Stick logger does not have a network. 2.Router WiFi signal strength weak.	1.Check if the wireless network configured. 2.Enhance router WiFi signal strength.
Slow flash	ON	Slow flash	Connection between logger and router normal, connection between logger and remote server abnormal.	1.Router networking abnormal. 2.The server point of logger is modified. 3.Network limitation, server cannot be connected.	1.Check if the router has access to the network. 2.Check the router's setting, if the connection is limited. 3.Contact our customer service.
OFF	OFF	OFF	Power supply abnormal	1.Connection between stick logger and inverter loosen or abnormal. 2.Inverter power insufficient. 3.Stick Logger abnormal.	1.Check the connection, remove the stick logger and install again. 2.Check inverter output power. 3.Contact our customer service.
Fast flash	Any state	Any state	Networking status	Normal	1.Exit automatically after 2mins. 2.Long press Reset button for 5s, reboot stick logger. 3.Long press Reset button for 10s, restore factory settings.
Any state	Any state	Fast flash	Restore factory settings	Normal	1.Exit automatically after 1mins. 2.Long press Reset button for 5s, reboot stick logger. 3.Long press Reset button for 10s, restore factory settings.

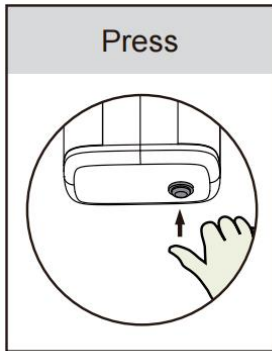

Key-press	Status Description	Light Status
Long press 5s then release	Rebooting the stick logger.	All lights are extinguished immediately.
Long press 10s then release	Resetting the stick logger.	1.All lights are extinguished after 4s. 2.READY light flashes fast for 100ms.



**Warning:**

Please do not hold the logger body to rotate while install or remove the logger.

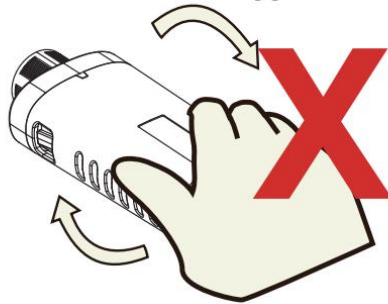

**Notice:**

Do not remove waterproof plug.



# 7. Fault and Remedy

## 7.1 Fault Codes

Fault Code	Fault name	Whether it affects the output or not	Description
01	BatVoltLow	NO	Battery undervoltage alarm.
02	BatOverCurrSw	YES	Battery discharge average current overcurrent (software protection).
03	BatOpen	YES	Battery not-connected alarm.
04	BatLowEod	YES	Battery undervoltage stop discharge alarm.
05	BatOverCurrHw	YES	Battery overcurrent (hardware protection).
06	BatOverVolt	YES	Charging overvoltage protection.
07	BusOverVoltHw	YES	Bus overvoltage (hardware protection).
08	BusOverVoltSw	YES	Bus overvoltage (software protection).
09	PvVoltHigh	NO	PV overvoltage protection.
10	ArcFault	YES	AFCI Arc fault.
11	PvBoostOCHw	NO	Boost overcurrent hardware protection.
12	SpiCommErr	YES	Master-slave SPI communication failure.
13	OverloadBypass	YES	Bypass overload protection.
14	Overload Inverter	YES	Inverter overload protection.
15	AcOverCurrHw	YES	Inverter overcurrent hardware protection.
16	AuxDSpReqOffPWM	YES	Slave chip OFF request fault.
17	InvShort	YES	Inverter short circuit protection.
18	Bussoftfailed	YES	Bus soft-start failure.
19	OverTemperTrans	YES	Transformer radiator over-temperature protection.
20	OverTemperInv	YES	Inverter radiator over-temperature protection.
21	FanFail	YES	Fan failure.
22	EEPROM	YES	Memory failure.
23	Model NumErr	YES	Model setting error.
24	Busdiff	YES	Positive and negative bus voltage imbalance.
25	BusShort	YES	Bus short circuit.
26	Rlyshort	YES	Inverter AC output backfeed to bypass AC output.
27	LinePhaselose	YES	Grid input phase lose.
28	LinePhaseErr	YES	Grid input phase error.
29	BusVoltLow	YES	Low bus voltage protection.
30	BatCapacityLow1	NO	Alarm given when battery capacity rate is lower than 10% (setting BMS to enable validity).
31	BatCapacityLow2	NO	Alarm given when battery capacity rate is lower than 5% (setting BMS to enable validity).

32	BatCapacityLowStop	YES	Inverter stops when battery capacity is low (setting BMS to enable validity).
33	ControlCanFault	YES	Control CAN fault in parallel operation.
34	CanCommFault	YES	CAN communication fault in parallel operation.
35	ParaAddrErr	YES	Parallel ID ( communication address ) setting error.
36	Balance currentOC	YES	Balanced bridge arm overcurrent fault.
37	ParaShareCurrErr	YES	Current distribution fault in parallel operation.
38	ParaBattVoltDiff	YES	Parallel mode, inconsistent utility input source.
39	ParaAcSrcDiff	YES	Inconsistent AC input source in parallel mode.
40	ParaHwSynErr	YES	Hardware synchronization signal error in parallel mode.
41	InvDcVoltErr	YES	Inverter DC voltage error.
42	SysFwVersionDiff	YES	Inconsistent system firmware version in parallel mode.
43	ParaLineContErr	YES	Parallel line connection error in parallel mode.
44	Serial number error	YES	No serial number set at factory.
45	Error setting of split-phase mode	YES	Item "Parallel" setting error.
49	Grid over voltage	YES	Grid voltage too high.
50	Grid under voltage	YES	Grid voltage too low.
51	Grid over Frequency	YES	Grid frequency too high.
52	Grid under Frequency	YES	Grid frequency too low.
53	Grid loss	YES	Grid voltage loss.
54	Grid DC current over	YES	Excessive DC component in grid current.
55	Grid standard un init	YES	Grid-Connection standard micro-initialization.
56	Low insulation resistance fault	NO	PV1+, PV2+, PV3+, PV- impedance to ground abnormally low.
57	Leakage current overload fault	YES	System leakage current exceeds the standard.
58	BMSComErr	NO	BMS communication error.
60	BMSUnderTem	NO	BMS low temperature alarm (effective after successful BMS communication).
61	BMSOverTem	YES	BMS over-temperature alarm (effective after successful BMS communication).
62	BMSOverCur	YES	BMS overcurrent alarm (effective after successful BMS communication).
63	BMSUnderVolt	NO	BMS undervoltage alarm (effective after successful BMS communication).

## 7.2 Troubleshooting

Fault Code	Meaning	Causes	Remedy
/	No screen display	No power input, or the switch on the bottom of the unit is not switched on.	Check whether the battery air circuit-breaker or PV air circuit-breaker is turned on. Check if the switch is "ON". Press any button on the screen to exit the screen sleep mode.
01	Battery undervoltage protection	Battery voltage is lower than the parameter setting value.	Wait until the battery charge is restored to above the low voltage disconnection recovery voltage.
03	Battery not connected	The battery is not connected, or the BMS is in discharge protection state.	Check that the battery is reliably connected. Check that the battery circuit-breaker is off. Ensure that the BMS is able to communicate properly.
04	Battery over-discharge protection voltage	The battery voltage is lower than the value set in <b>【Battery Setup】</b> - <b>【Battery Discharge】</b> - <b>【Batt. voltage low fault】</b> .	Manual reset: Turn off and restart. Automatic reset: Charge the battery so that the battery voltage is higher than the voltage set in the parameter item <b>【Battery Setup】</b> - <b>【Battery Discharge】</b> - <b>【Battery Recovery Voltage】</b> .
06	Battery over-voltage when charging	Battery is in over-voltage condition.	Manually power off and restart. Check to see if the battery voltage exceeds the limit. If it exceeds, the battery needs to be discharged until the voltage is below the battery over-voltage recovery point.
13	Bypass over-load (software detection)	Bypass output power or output current over-load for a period of time.	Reduce the load power and restart the device.
14	Inverter over-load (software detection)	Inverter output power or output current over-load for a period of time.	
19	Heat sink of PV input over-temperature (software detection)	Heat sink of PV input temperature exceeds 90°C for 3s.	Normal charging and discharging is resumed when the temperature of the heat sink cools below the over-temperature recovery temperature.
20	Heat sink of inverter output over-temperature (software detection)	Heat sink of inverter output temperature exceeds 90°C for 3s.	
21	Fan failure	Hardware detects fan failure.	Manually toggle the fan after powering off the machine to check for foreign matter blockage.
26	AC input relay short-circuit	Relay for AC input sticking.	Manually turn off and restart the machine, if the fault reappears after restarting, you need to contact the after-sales service to repair the machine.
28	Utility input phase fault	AC input phase does not match AC output phase.	Make sure that the phase of the AC input is the same as the phase of the AC output.

**NOTICE**

If you encounter product faults that cannot be solved by the methods in the above table, please contact our after-sales service department for technical support and do not disassemble the equipment by yourself.

# 8. Protection and Maintenance

## 8.1 Protection Functions

No.	Protection Functions	Description
1	PV input current limiting protection	When the charging current or power of the PV array configured exceeds the PV input rated value, the inverter will limit the input power and charge at the rated.
2	PV input over-voltage	If the PV voltage exceeds the maximum value allowed by the hardware, the machine reports a fault and stops PV boosting to output a sinusoidal AC waveform.
3	Anti-reverse charge protection at night	At night, the battery will be prevented from discharging to the PV module because the battery voltage is greater than the PV module voltage.
4	AC input over-voltage protection	When the mains phase voltage exceeds 140Vac, mains charging will stop and the inverter will switch to output mode.
5	AC input under-voltage protection	When the mains phase voltage falls below 90Vac, mains charging will stop and the inverter will switch to output mode.
6	Battery over-voltage protection	When the battery voltage reaches the over-voltage disconnection voltage point, it will automatically stop the PV and mains charging of the battery to prevent over-charging and damage to the battery.
7	Battery under-voltage protection	When the battery voltage reaches the low-voltage disconnection voltage point, it will automatically stop discharging the battery to prevent the battery from being over-discharged and damaged.
8	Battery over-current protection	When the battery current exceeds the range allowed by hardware, the machine will turn off output and stop discharging the battery.
9	AC output short-circuit protection	When a short-circuit fault occurs at the load, the AC output voltage will be switched off immediately and output again after 1 min. If the output load is still short-circuited after 3 attempts, short-circuit fault of the load must be eliminated first and then manually re-powered in order to restore the normal output.
10	Heat sink over-temperature protection	When the internal temperature of the inverter is too high, the inverter will stop charging and discharging; when the temperature returns to normal, the inverter will resume charging and discharging.
11	AC output reverse	Prevents backfeeding of battery inverter AC to bypass AC inputs.
12	Bypass over-current protection	Built-in AC input overcurrent protection circuit breaker.
13	Bypass phase inconsistency protection	When the phase of the two bypass inputs is different from the phase of the inverter phase split, the machine will prohibit cutting into the bypass to prevent the load from dropping out or short-circuiting when cutting into the bypass.
14	Arc fault circuit interrupter protection (AFCI)	Its primary function is to detect whether electric arcs occur in the wires between the PV modules and the inverter, as well as between PV modules themselves, due to aging or other factors. This protection mechanism prevents fire hazards caused by electric arcs; once an arc is detected, the inverter will immediately shut down its operation to activate protective measures.
15	Anti-Islanding protection	It serves as a safety switch for the power system. When the grid suffers a sudden power outage, it will quickly disconnect the inverter from the grid, preventing the formation of an island and ensuring the safety of maintenance personnel as well as the normal operation of the equipment.

## 8.2 Maintenance

**To maintain optimum long-lasting working performance, it is recommended that the following items be checked twice a year.**

1. Ensure that the airflow around the inverter is not blocked and remove any dirt or debris from the radiator.
2. Check that all exposed conductors are not damaged by sunlight, friction with other surrounding objects, dry rot, insect or rodent damage, etc. The conductors need to be repaired or replaced if necessary.
3. Verify that the indications and displays are consistent with the operation of the equipment, note any faults or incorrect displays and take corrective action if necessary.
4. Check all terminals for signs of corrosion, insulation damage, high temperatures or burning/discolouration and tighten terminal screws.
5. Check for dirt, nesting insects and corrosion, clean as required, clean insect screens regularly.
6. If the lightning arrester has failed, replace the failed arrester in time to prevent lightning damage to the inverter or other equipment of the user.

 **DANGER**

Make sure that the inverter is disconnected from all power sources and that the capacitors are fully discharged before carrying out any checks or operations to avoid the risk of electric shock.

## 8.3 Storage

**If the inverter is not to be put into use immediately, the following requirements shall be met for storage:**

- Do not remove the original packaging of the inverter.
- The storage temperature shall be maintained at  $-40 \sim +70^{\circ}\text{C}$  ( $-40 \sim 158^{\circ}\text{F}$ ); the relative humidity shall be maintained at  $5\% \sim 95\% \text{RH}$ .
- Store in a clean and dry place to protect against dust and moisture erosion.
- Maximum stacking height: 4 layers. When stacking, place the inverters with care to prevent tipping over, which may cause personal injury or equipment damage.
- Conduct regular inspections during storage (recommended once every three months). Replace the packaging materials in a timely manner if moth damage, rat bites or packaging damage is found.
- If the storage period is 2 years or longer, the inverter must be inspected and tested by professional personnel before being put into use.

# 9. Datasheet

Models	HEBP48150U320-H	HEBP48160U340-H	HEBP48180U380-H	Adjustable
<b>AC Output (Load)</b>				
Rated Output Power	15000W	16000W	18000W	
Max. Peak Power (off-grid)	30000VA	32000VA	36000VA	
Rated Output Voltage	120/240Vac (single-phase); 120/208V (three-phase)			√
Output Voltage Error	± 5%			
Rated Frequency	50/60Hz ±0.3Hz			√
Waveform	Pure sine wave			
Switch Time	10ms (Typical)			
<b>AC Output (On-grid)</b>				
Rated Output Power	15000W	16000W	18000W	
Max. Apparent Power	16500VA	17600VA	19800VA	
Power Factor	0.8 leading to 0.8 lagging			
Motor Load Capacity	7HP	8HP	9HP	
Locked Rotor Current (LRA)	188A			
Rated Output Voltage	120/240Vac (L1+L2+N+PE)			
Rated AC Output Frequency	50/60Hz			
Rated AC Output Current	62.5Aac	66.7Aac	75Aac	
THD	<3%			
<b>Battery Data</b>				
Battery Type	Lithium-ion Battery / Lead-acid Battery / User-defined			√
Rated Battery Voltage	48Vdc			
Battery Voltage Range	40-60Vdc			
Max. Generator Charging Current	320Aac	340Aac	380Aac	√
Max. Grid Charging Current	320Aac	340Aac	380Aac	√
Max. Hybrid Charging Current	320Aac	340Aac	380Aac	√
Charging Strategy for Li-ion Battery	Self-adaption to BMS			
<b>PV Input</b>				
No. of MPPT Trackers	3			
No. of Strings MPPT Tracker	2+2+2			
Max. PV Access Power	30000W	32000W	36000W	
Max. PV Input Power	24000W	25600W	28800W	
Max. PV Input Current	42A/42A/42A			
Max. Input Short-Circuit Current	63A/63A/63A			
Max. PV Input Voltage	600V			

MPPT Operating Voltage Range	120V ~ 500V	
<b>Grid/Generator Input</b>		
Input Voltage Range	Phase Voltage: 90V~140V; Line Voltage: 180V~280V	
Input Frequency Range	40-70Hz	
Max. Bypass Overload Current (Grid)	200A	
<b>Efficiency</b>		
MPPT Tracking Efficiency	99.9%	
Max. Efficiency	≥97.5%	
European Efficiency	97%	
<b>Protection</b>		
PV Input Lightning Protection	Yes	
Anti-islanding Protection	Yes	
PV Input Reverse Polarity Protection	Yes	
Insulation Resistor Detection	Yes	
Residual Current Monitoring Unit	Yes	
Output Over Current Protection	Yes	
Output Shorted Protection	Yes	
Arc fault circuit interrupter Protection(AFCI)	Yes	
Surge Protection	DC type II/AC type II	
Overvoltage Category	DC type II/AC type III	
<b>Certification</b>		
Certificate	UL 1741-2021 (UL1741SB), CSA C22.2 No 107.1-16, IEC62109-1, IEC62109-2, EN61000-6-1, EN61000-6-3, FCC 15 class B	
RoHS	Yes	
<b>General Data</b>		
Parallel Capacity	9	
Operating Temperature	-40 ~ 140 °F, >113°F derated	
Humidity Range	0 ~ 100%	
Noise	<55dB	
Protection Degree	IP65	
Cooling Method	Heat sink + intelligent air cooling	
Standby Power Consumption	70W	
Dimensions	33.86×18.90×12.32 in	
Weight	142.64 lbs	
Communication Interface	RS485 / CAN / USB / Dry contact	√
External Modules	Wi-Fi / 4G Stick (Optional)	√





---

**SRNE Solar Co.,Ltd**

---

Mail	master@szshuori.com
Web	www.srnesolar.com
Address	4-5F,Building13A,Taihua Wutong Industrial Park ,Gushu Development Zone , Hangcheng Street,Baoan, Shenzhen, China PR

